

970-094
SECTION NO.

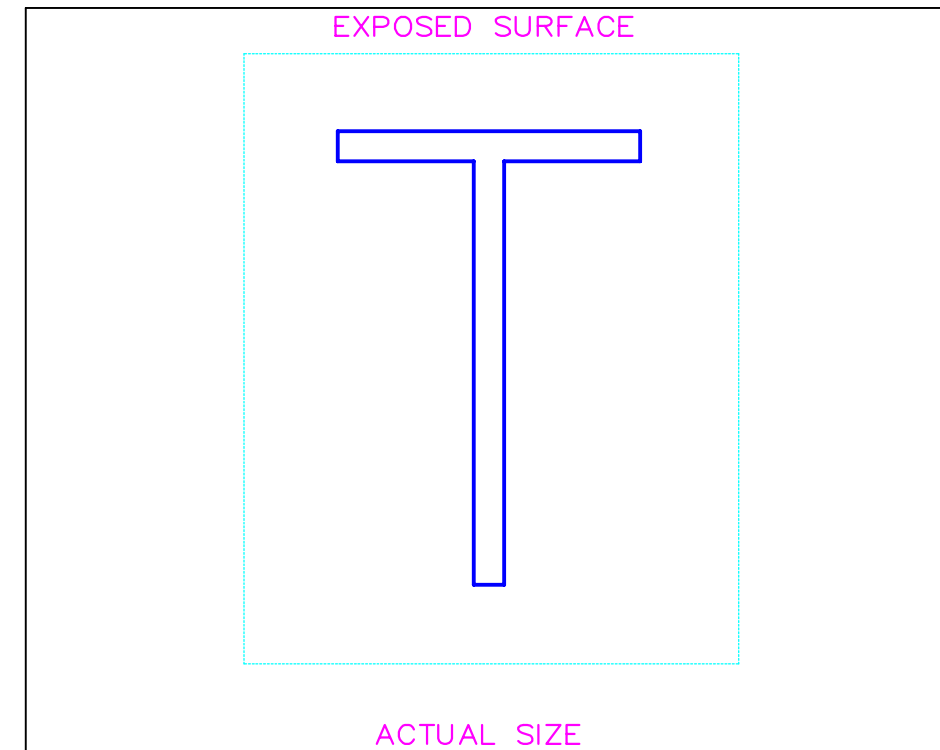
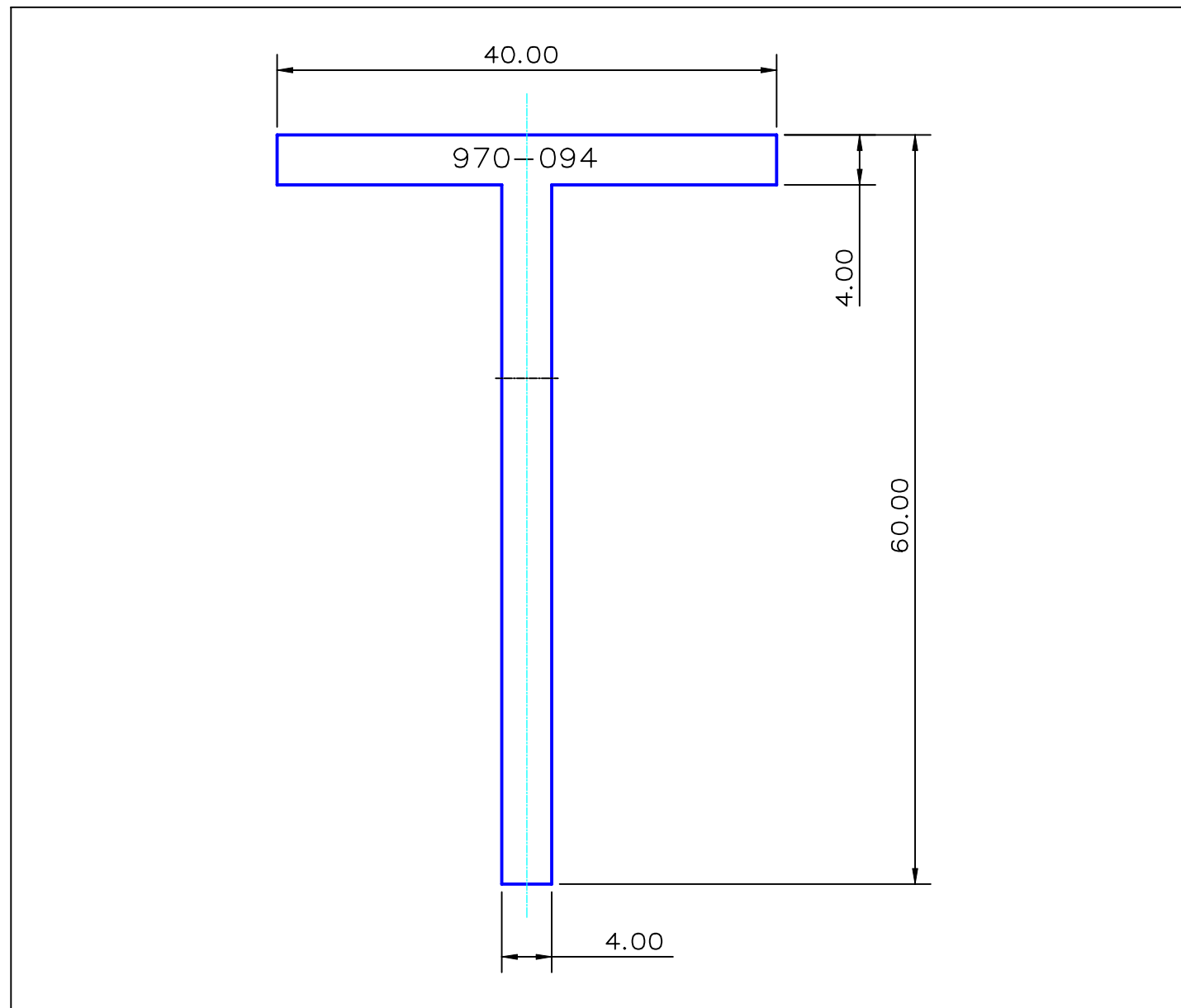

MOMENTS OF INERTIA:
 $I_{xx} = 142752 \text{ mm}^4$
 $I_{yy} = 21632 \text{ mm}^4$

0.40 RADIUS ON ALL OUTSIDE CORNERS
UNLESS OTHERWISE SPECIFIED

EXTRUDED FINISH : ARCHITECTURAL

NO	DATE	DR	REVISION

AREA	384.0	SQ MM
WEIGHT	1.041	KG M
PERIMETER	200.0	MM
ANOD PERIM	200.0	MM
PAINT PERIM	200.0	MM
C CIRCLE DIA	67	MM
FACTOR	192	
ALLOY	6351	
TEMPER	T5	

G. James Extrusion Co.
 A.C.N 010 828 234
 1082 KINGSFORD SMITH DRIVE, EAGLE FARM, QUEENSLAND, 4009
 PO BOX 1376, EAGLE FARM BC, 4009
 PHONE : (07) 3877 2833 FAX : (07) 3877 2890

CUSTOMER			
G.JAMES EXTRUSION			
CUSTOMER PART NAME		NO.	
40 x 60 x 4 T SECTION			
SCALE		TOLERANCES IN ACCORDANCE WITH AS 1866-1986 APPLY UNLESS OTHERWISE SPECIFIED	
2:1			
DRAWN	CHECK	DATE	DWG. NO.
JSO		04/01/94	970-094