

SECTION NO.
960-030

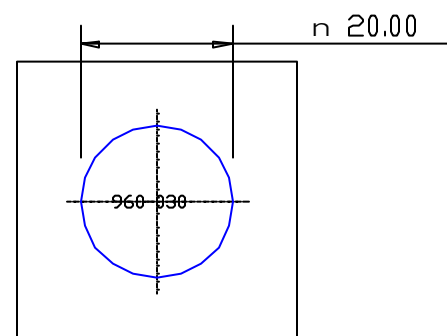

TOTAL SURFACE EXPOSED

SECTION DATA:
 $I_{xx} = 7\,854 \text{ mm}^4$
 $I_{yy} = 7\,854 \text{ mm}^4$
 $\text{Theta} = 0.0^\circ$
 $\text{RadG}_x = 5. \text{ mm}$
 $\text{RadG}_y = 5. \text{ mm}$
 $\text{XC}_{\text{Right}} = 10.0 \text{ mm}$
 $\text{XC}_{\text{Left}} = 10.0 \text{ mm}$
 $\text{YC}_{\text{top}} = 10.0 \text{ mm}$
 $\text{YC}_{\text{bot}} = 10.0 \text{ mm}$
 $Z_{xx\text{top}} = 785 \text{ mm}^3$
 $Z_{xx\text{bot}} = 785 \text{ mm}^3$
 $Z_{yy\text{right}} = 785 \text{ mm}^3$
 $Z_{yy\text{left}} = 785 \text{ mm}^3$

0.40 RADIUS ON ALL OUTSIDE CORNERS
UNLESS OTHERWISE SPECIFIED

EXTRUDED FINISH : ARCHITECTURAL

				AREA 314.2 SQ MM WEIGHT 0.851 KG M PERIMETER 62.8 MM ANOD PERIM 62.8 MM PAINT PERIM 100.0 (0.0) MM C CIRCLE DIA 20.0 MM FACTOR 74. ALLOY 6351 TEMPER T6	 A.C.N 010 828 234 1082 KINGSFORD SMITH DRIVE, EAGLE FARM, QUEENSLAND, 4009 PO BOX 1376, EAGLE FARM BC, 4009 PHONE : (07) 3877 2833 FAX : (07) 3877 2890		CUSTOMER G. JAMES EXTRUSION Co.		
				CUSTOMER PART NAME NO. 20mm DIA ROUND SOLID		SCALE 1:1			
						TOLERANCES IN ACCORDANCE WITH AS 1866-1986 APPLY UNLESS OTHERWISE SPECIFIED			
NO	DATE	DR	REVISION			DRAWN BPW	CHECK	DATE 24/10/89	DWG. NO. 960-030