

SECTION NO.

941-010

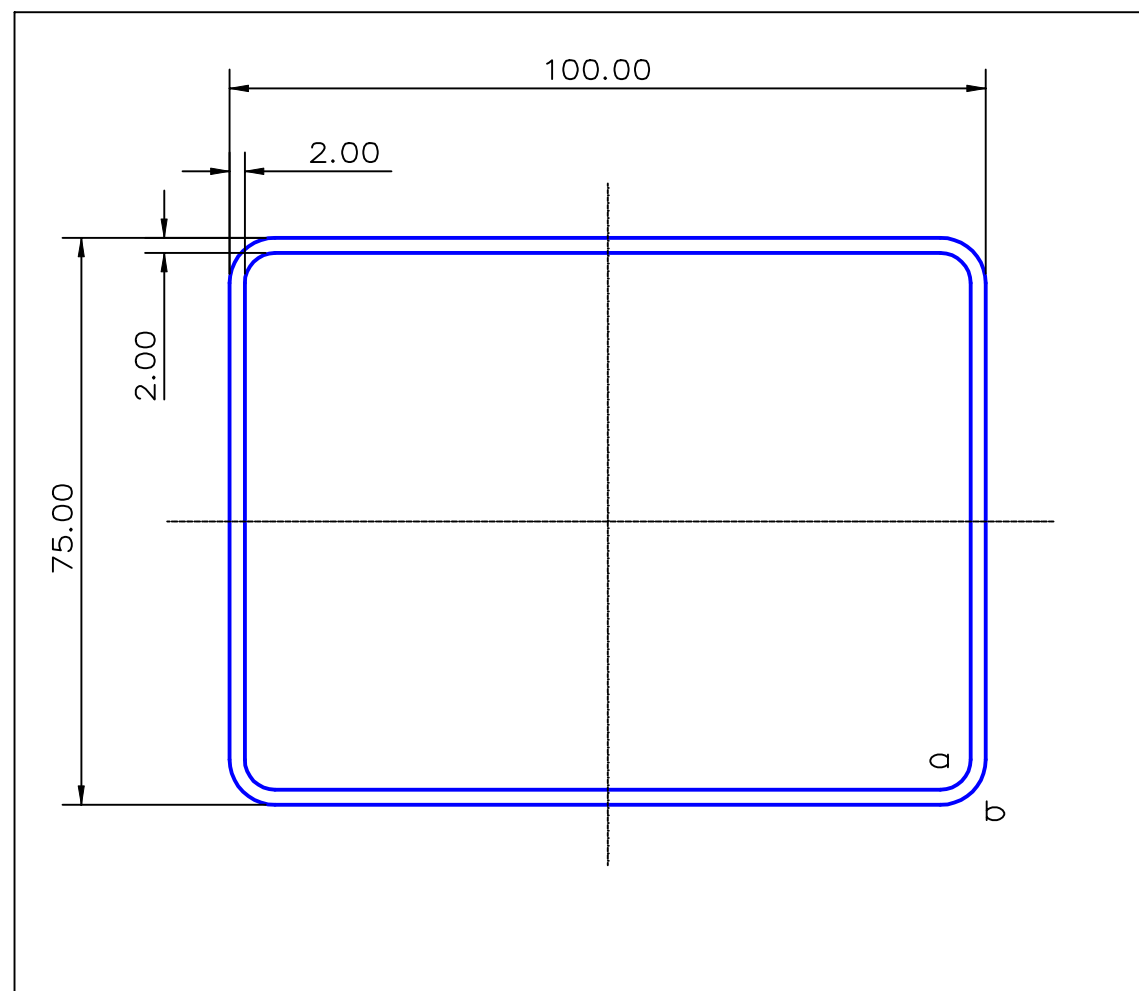

TOTAL EXPOSED SURFACE

SECTION DATA:

$I_{xx} = 628\,348 \text{ mm}^4$
 $I_{yy} = 972\,587 \text{ mm}^4$
 $\text{Theta} = 1.0$
 $\text{RadG}_x = 31. \text{ mm}$
 $\text{RadG}_y = 38. \text{ mm}$
 $X_{\text{Left}} = 50.00 \text{ mm}$
 $X_{\text{Right}} = 50.00 \text{ mm}$
 $Y_{\text{Top}} = 37.50 \text{ mm}$
 $Y_{\text{Bot}} = 37.50 \text{ mm}$
 $Z_{xx\text{top}} = 16\,756 \text{ mm}^3$
 $Z_{xx\text{bot}} = 16\,756 \text{ mm}^3$
 $Z_{yy\text{left}} = 19\,452 \text{ mm}^3$
 $Z_{yy\text{right}} = 12\,567 \text{ mm}^3$

a = 4.00 radius

b = 6.00 radius

0.40 RADIUS ON ALL OUTSIDE CORNERS
UNLESS OTHERWISE SPECIFIED

EXTRUDED FINISH : ARCHITECTURAL

A

AREA	666.8	SQ MM
WEIGHT	1.807	KG M
PERIMETER	666.8	MM
ANOD PERIM	339.7	MM
PAINT PERIM	339.7	MM
C CIRCLE DIA	120.	MM
FACTOR	369.	
ALLOY	6063	
TEMPER	T6	

**G. James
Extrusion Co.**

A.C.N 010 828 234

1082 KINGSFORD SMITH DRIVE, EAGLE FARM, QUEENSLAND, 4009

PO BOX 1376, EAGLE FARM BC, 4009

PHONE : (07) 3877 2833 FAX : (07) 3877 2890

CUSTOMER

G.JAMES EXTRUSION Co.

CUSTOMER PART NAME

NO.

100 x 75 x 2 RECT. BOX R/C

SCALE

1:1

TOLERANCES IN ACCORDANCE WITH AS 1866-1986
APPLY UNLESS OTHERWISE SPECIFIED

DRAWN

BJC

CHECK

DATE

02/06/88

DWG. NO.

941-010

NO

DATE

DR

REVISION