

SECTION NO.  
940-070

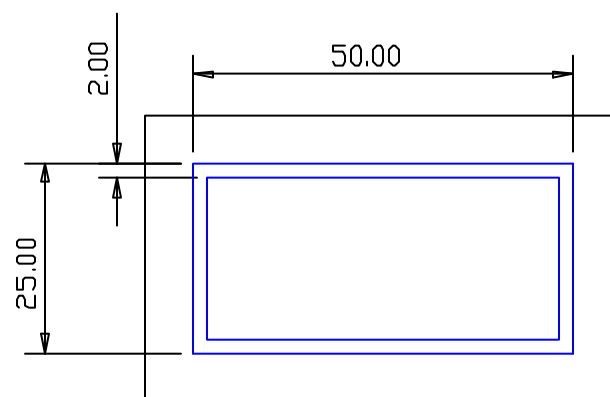

TOTAL SURFACE EXPOSED

SECTION DATA:

$I_{xx} = 29\,604\text{ mm}^4$   
 $I_{yy} = 90\,079\text{ mm}^4$   
 $\text{Theta} = 1.0^\circ$   
 $\text{RadG}_x = 10\text{ mm}$   
 $\text{RadG}_y = 18\text{ mm}$   
 $\text{XC}_{\text{Right}} = 25.0\text{ mm}$   
 $\text{XC}_{\text{Left}} = 25.0\text{ mm}$   
 $\text{YC}_{\text{top}} = 12.5\text{ mm}$   
 $\text{YC}_{\text{bot}} = 12.5\text{ mm}$   
 $\text{Z}_{xx\text{top}} = 2\,368\text{ mm}^3$   
 $\text{Z}_{xx\text{bot}} = 2\,368\text{ mm}^3$   
 $\text{Z}_{yy\text{right}} = 3\,603\text{ mm}^3$   
 $\text{Z}_{yy\text{left}} = 3\,603\text{ mm}^3$

0.40 RADIUS ON ALL OUTSIDE CORNERS  
UNLESS OTHERWISE SPECIFIED

EXTRUDED FINISH + ARCHITECTURAL

			A		AREA 284.0 WEIGHT 0.770 PERIMETER 284.0 ANOD PERIM 50.0 PAINT PERIM 50.0 (0.0) C CIRCLE DIA 56 FACTOR 369 ALLOY 6063 TEMPER T6	SQ MM KG M MM MM MM	 A.C.N 010 828 234 1082 KINGSFORD SMITH DRIVE, EAGLE FARM, QUEENSLAND, 4009 PO BOX 1376, EAGLE FARM BC, 4009 PHONE : (07) 3877 2833 FAX : (07) 3877 2890	CUSTOMER		G. JAMES EXTRUSION Co.	
								CUSTOMER PART NAME NO.		50 x 25 x 2 RECT. BOX	
							SCALE		TOLERANCES IN ACCORDANCE WITH AS 1866-1986 APPLY UNLESS OTHERWISE SPECIFIED		
							1:1				
NO	DATE	DR	REVISION				DRAWN	CHECK	DATE	DWG. NO.	
							A.T		06/03/87	940-070	