

SECTION NO.

930-079

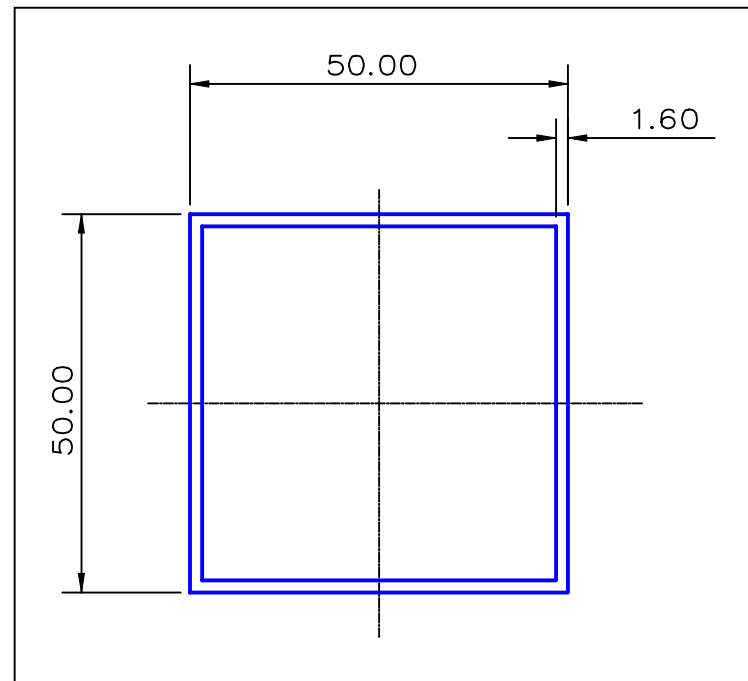

TOTAL SURFACE EXPOSED

SECTION DATA:  
 $I_{xx} = 121\ 071\ \text{mm}^4$   
 $I_{yy} = 121\ 071\ \text{mm}^4$   
 $\text{Theta} = 0.0$   
 $\text{RadG}_x = 20.0\ \text{mm}$   
 $\text{RadG}_y = 20.0\ \text{mm}$   
 $X_{\text{Left}} = 25.0\ \text{mm}$   
 $X_{\text{Right}} = 25.0\ \text{mm}$   
 $Y_{\text{Top}} = 25.0\ \text{mm}$   
 $Y_{\text{Bot}} = 25.0\ \text{mm}$   
 $Z_{xx\ \text{top}} = 4\ 843\ \text{mm}^3$   
 $Z_{xx\ \text{bot}} = 4\ 843\ \text{mm}^3$   
 $Z_{yy\ \text{left}} = 4\ 843\ \text{mm}^3$   
 $Z_{yy\ \text{right}} = 4\ 843\ \text{mm}^3$

0.40 RADIUS ON ALL OUTSIDE CORNERS  
 UNLESS OTHERWISE SPECIFIED

EXTRUDED FINISH : ARCHITECTURAL

			A	AREA 309.8 WEIGHT 0.839 PERIMETER 387.2 ANOD PERIM 200.0 PAINT PERIM 200.0 C CIRCLE DIA 71. FACTOR 461. ALLOY 6063 TEMPER T6	SQ MM KG M MM MM MM	 A.C.N 010 828 234 1082 KINGSFORD SMITH DRIVE, EAGLE FARM, QUEENSLAND, 4009 PO BOX 1376, EAGLE FARM BC, 4009 PHONE : (07) 3877 2833 FAX : (07) 3877 2890	CUSTOMER		G. JAMES EXTRUSION Co.	
							CUSTOMER PART NAME		NO. 50 x 1.6 SQUARE BOX	
						SCALE		TOLERANCES IN ACCORDANCE WITH AS 1866-1986 APPLY UNLESS OTHERWISE SPECIFIED		
						1:1				
NO	DATE	DR	REVISION			DRAWN	CHECK	DATE	DWG. NO.	
						BPW		22/02/91	930-079	