

SECTION NO.  
930-031

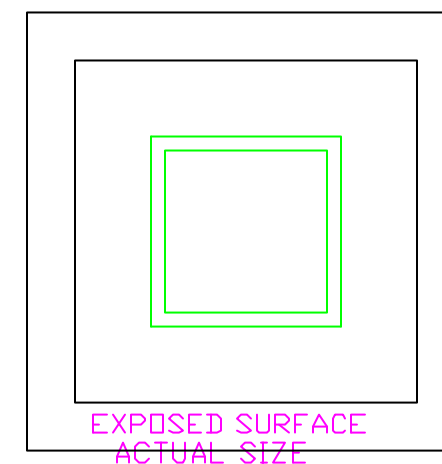
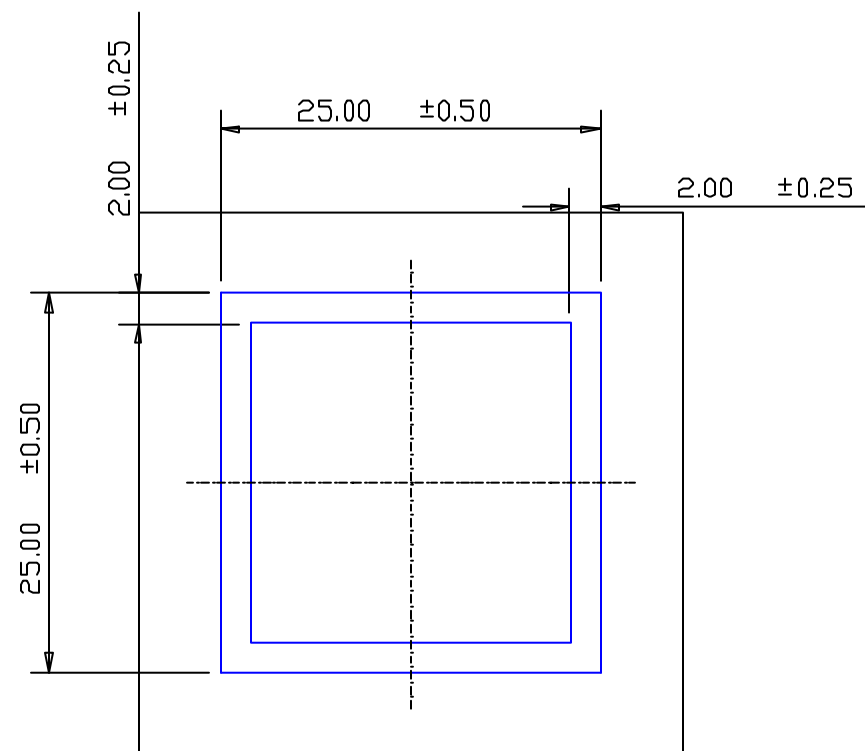

SECTION DATA:  
 $I_{xx} = 16\,345\text{ mm}^4$   
 $I_{yy} = 16\,345\text{ mm}^4$   
 $\text{Theta} = 1.0^\circ$   
 $\text{RadG}_x = 9\text{ mm}$   
 $\text{RadG}_y = 9\text{ mm}$   
 $\text{XC}_{\text{Right}} = 12.5\text{ mm}$   
 $\text{XC}_{\text{Left}} = 12.5\text{ mm}$   
 $\text{YC}_{\text{Top}} = 12.5\text{ mm}$   
 $\text{YC}_{\text{Bot}} = 12.5\text{ mm}$   
 $\text{Z}_{xx\text{top}} = 1\,308\text{ mm}^3$   
 $\text{Z}_{xx\text{bot}} = 1\,308\text{ mm}^3$   
 $\text{Z}_{yy\text{right}} = 1\,308\text{ mm}^3$   
 $\text{Z}_{yy\text{left}} = 1\,308\text{ mm}^3$

0.40 RADIUS ON ALL OUTSIDE CORNERS  
UNLESS OTHERWISE SPECIFIED

EXTRUDED FINISH + ARCHITECTURAL

			<p>A</p> <p>AREA 184.0 SQ MM          WEIGHT 0.499 KG M          PERIMETER 184.0 MM          ANOD PERIM 100.0 MM          PAINT PERIM 100.0 (0.0) MM          C CIRCLE DIA 5 MM          FACTOR 369          ALLOY 6063          TEMPER T5</p>		 <p>G. James Extrusion Co.</p> <p>A.C.N 010 828 234          1082 KINGSFORD SMITH DRIVE, EAGLE FARM, QUEENSLAND, 4009          PO BOX 1376, EAGLE FARM BC, 4009          PHONE : (07) 3877 2833 FAX : (07) 3877 2890</p>		CUSTOMER		
							G. JAMES EXTRUSION Co.		
					CUSTOMER PART NAME NO.				
					25.0 x 2.0 SQUARE BOX				
					SCALE	TOLERANCES IN ACCORDANCE WITH AS 1866-1986 APPLY UNLESS OTHERWISE SPECIFIED			
					2:1				
NO	DATE	DR	REVISION			DRAWN	CHECK	DATE	DWG. NO.
						SPG		06/10/00	930-031