

SECTION NO.
950-307

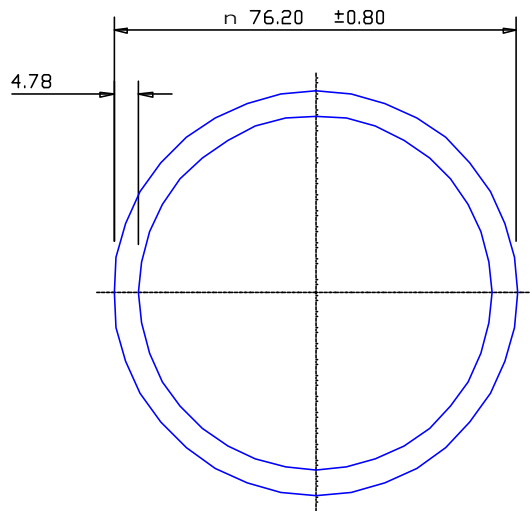

TOTAL SURFACE EXPOSED

SECTION DATA:

$I_{xx} = 686\,892\text{ mm}^4$
 $I_{yy} = 686\,892\text{ mm}^4$
 $\text{Theta} = 0^\circ$
 $\text{RadG}_x = 25\text{ mm}$
 $\text{RadG}_y = 25\text{ mm}$
 $\text{XC}^{\text{Right}} = 38.1\text{ mm}$
 $\text{XC}^{\text{Left}} = 38.1\text{ mm}$
 $\text{YC}^{\text{Top}} = 38.1\text{ mm}$
 $\text{YC}^{\text{Bot}} = 38.1\text{ mm}$
 $Z_{xx}^{\text{top}} = 18\,029\text{ mm}^3$
 $Z_{xx}^{\text{bot}} = 18\,029\text{ mm}^3$
 $Z_{yy}^{\text{right}} = 18\,029\text{ mm}^3$
 $Z_{yy}^{\text{left}} = 18\,029\text{ mm}^3$

4.78±0.40 TYP WALL THICKNESS
UNLESS OTHERWISE SPECIFIED

0.40 RADIUS ON ALL OUTSIDE CORNERS
UNLESS OTHERWISE SPECIFIED

EXTRUDED FINISH - ARCHITECTURAL

			A		AREA 1072.5 SQ MM WEIGHT 2.906 KG M PERIMETER 448.7 MM ANOD PERIM 239.4 MM PAINT PERIM 239.4 (0.0) MM C CIRCLE DIA 6 MM FACTOR 154 ALLOY 606043 TEMPER T581	 A.C.N 010 828 234 1082 KINGSFORD SMITH DRIVE, EAGLE FARM, QUEENSLAND, 4009 PO BOX 1376, EAGLE FARM BC, 4009 PHONE : (07) 3877 2833 FAX : (07) 3877 2890	CUSTOMER G. JAMES EXTRUSION Co.		
					CUSTOMER PART NAME NO. 76.2 x 4.78 ROUND TUBE				
					SCALE 1:1	TOLERANCES IN ACCORDANCE WITH AS 1866-1986 APPLY UNLESS OTHERWISE SPECIFIED			
1	20/03/02	PAAD	SECTION WAS APE-063 C/N 4932			DRAWN BPW	CHECK	DATE 06/03/91	DWG. NO. 950-307
NO	DATE	DR	REVISION						