

SECTION NO.  
950-130

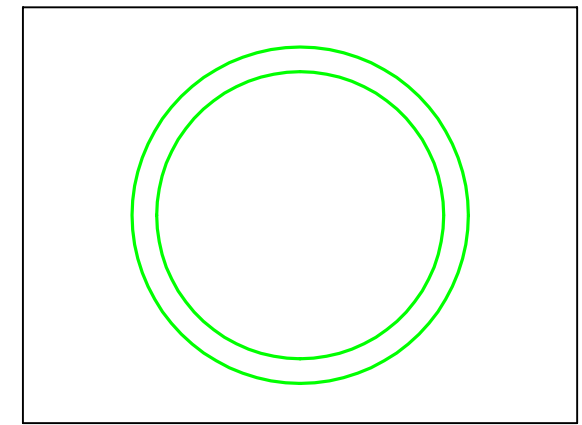
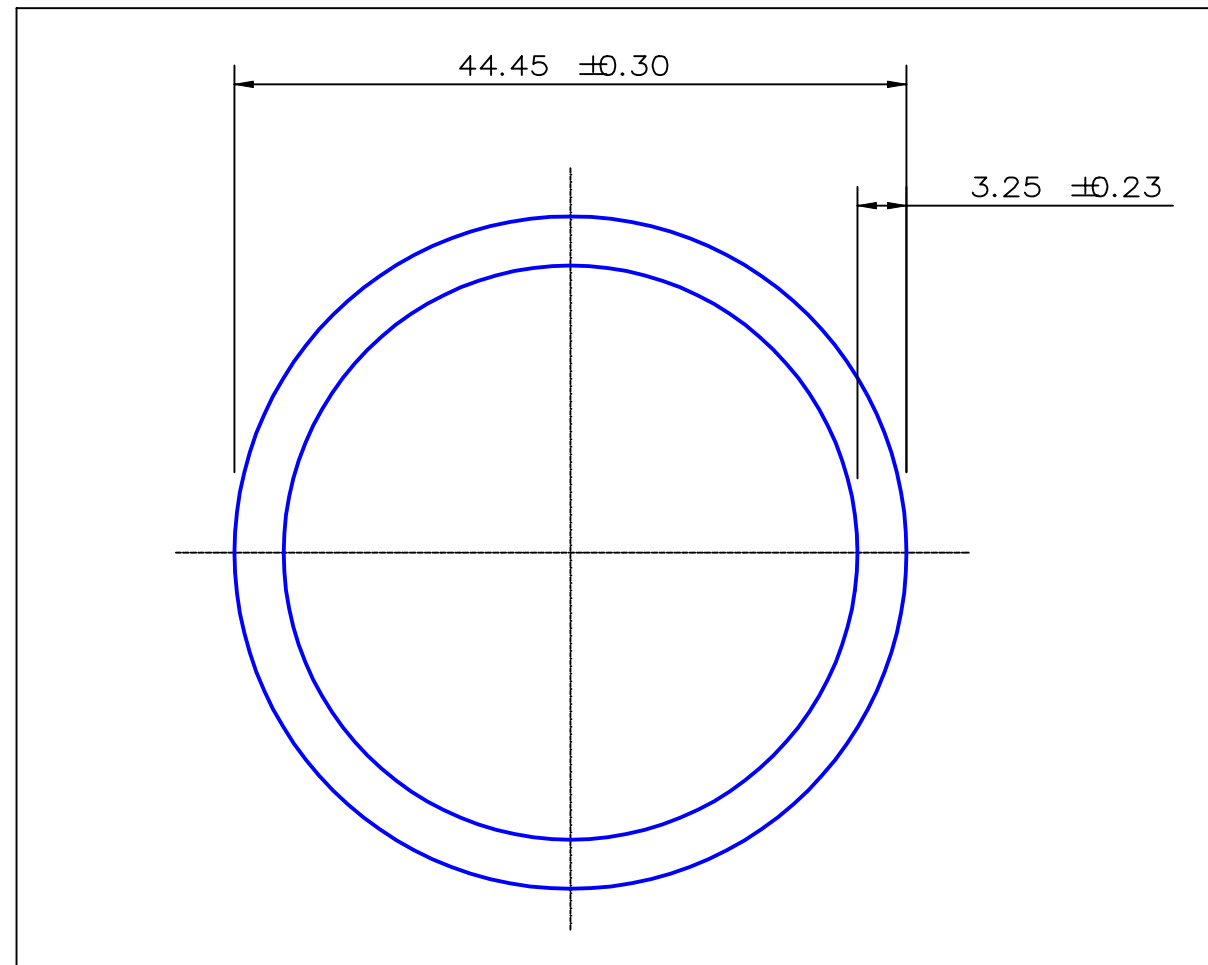

TOTAL EXPOSED SURFACE  
ACTUAL SIZE

SECTION DATA:  
 $I_{xx} = 89\,811 \text{ mm}^4$   
 $I_{yy} = 89\,811 \text{ mm}^4$   
 $\text{Theta} = 1.0^\circ$   
 $\text{RadG}_x = 15. \text{ mm}$   
 $\text{RadG}_y = 15. \text{ mm}$   
 $X_{\text{Left}} = 22.2 \text{ mm}$   
 $X_{\text{Right}} = 22.2 \text{ mm}$   
 $Y_{\text{Top}} = 22.2 \text{ mm}$   
 $Y_{\text{Bot}} = 22.2 \text{ mm}$   
 $Z_{xx}^{\text{top}} = 4.041 \text{ mm}^3$   
 $Z_{xx}^{\text{bot}} = 4.041 \text{ mm}^3$   
 $Z_{yy}^{\text{left}} = 4.041 \text{ mm}^3$   
 $Z_{yy}^{\text{right}} = 4.041 \text{ mm}^3$

0.40 RADIUS ON ALL OUTSIDE CORNERS  
UNLESS OTHERWISE SPECIFIED

EXTRUDED FINISH : ARCHITECTURAL

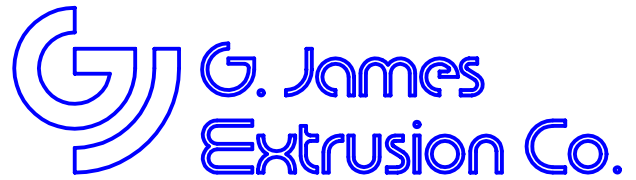
			A	AREA 420.7 SQ MM WEIGHT 1.140 KG M PERIMETER 258.9 MM ANOD PERIM 139.6 MM PAINT PERIM 139.6 MM C CIRCLE DIA 44. MM FACTOR 227. ALLOY 6063 TEMPER T6	 A.C.N 010 828 234 1082 KINGSFORD SMITH DRIVE, EAGLE FARM, QUEENSLAND, 4009 PO BOX 1376, EAGLE FARM BC, 4009 PHONE : (07) 3877 2833 FAX : (07) 3877 2890	CUSTOMER <b>G. JAMES EXTRUSION Co.</b>	
					CUSTOMER PART NAME NO. <b>44.45 x 3.25 ROUND TUBE</b>		
					SCALE <b>2:1</b>	TOLERANCES IN ACCORDANCE WITH AS 1866-1986 APPLY UNLESS OTHERWISE SPECIFIED	
NO	DATE	DR	REVISION		DRAWN <b>JWC</b>	CHECK DATE <b>06/04/87</b>	DWG. NO. <b>950-130</b>