

SECTION NO.
950-120

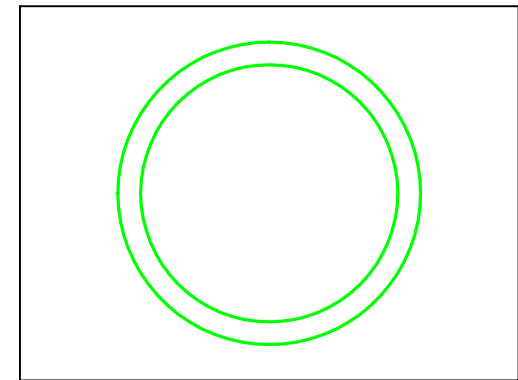
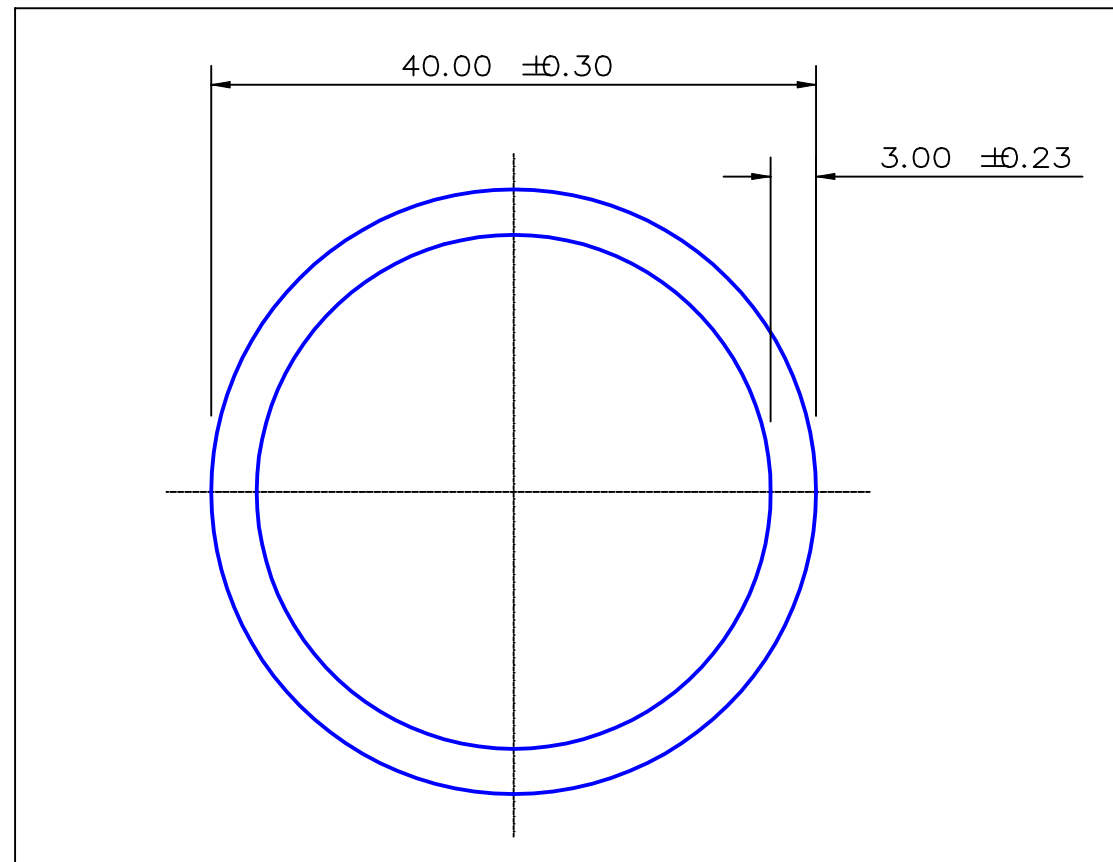

TOTAL EXPOSED SURFACE
ACTUAL SIZE

SECTION DATA:
 $I_{xx} = 60\,066 \text{ mm}^4$
 $I_{yy} = 60\,066 \text{ mm}^4$
 $\text{Theta} = 1.0$
 $\text{RadG}_x = 13. \text{ mm}$
 $\text{RadG}_y = 13. \text{ mm}$
 $\text{XC}_{\text{left}} = 20.0 \text{ mm}$
 $\text{XC}_{\text{right}} = 20.0 \text{ mm}$
 $\text{YC}_{\text{top}} = 20.0 \text{ mm}$
 $\text{YC}_{\text{bot}} = 20.0 \text{ mm}$
 $\text{Z}_{xx\text{top}} = 3\,003 \text{ mm}^3$
 $\text{Z}_{xx\text{bot}} = 3\,003 \text{ mm}^3$
 $\text{Z}_{yy\text{left}} = 3\,003 \text{ mm}^3$
 $\text{Z}_{yy\text{right}} = 3\,003 \text{ mm}^3$

0.40 RADIUS ON ALL OUTSIDE CORNERS
UNLESS OTHERWISE SPECIFIED

EXTRUDED FINISH : ARCHITECTURAL

			A	AREA 348.7 SQ MM WEIGHT 0.945 KG M PERIMETER 232.5 MM ANOD PERIM 125.7 MM PAINT PERIM 125.7 MM C CIRCLE DIA 40. MM FACTOR 246. ALLOY 6063 TEMPER T6	 A.C.N 010 828 234 1082 KINGSFORD SMITH DRIVE, EAGLE FARM, QUEENSLAND, 4009 PO BOX 1376, EAGLE FARM BC, 4009 PHONE : (07) 3877 2833 FAX : (07) 3877 2890	CUSTOMER G. JAMES EXTRUSION Co.		
					CUSTOMER PART NAME NO. 40 x 3.0 ROUND TUBE			
					SCALE 2:1	TOLERANCES IN ACCORDANCE WITH AS 1866-1986 APPLY UNLESS OTHERWISE SPECIFIED		
NO	DATE	DR	REVISION		DRAWN JWC	CHECK	DATE 06/04/87	DWG. NO. 950-120