

SECTION NO.

950-098

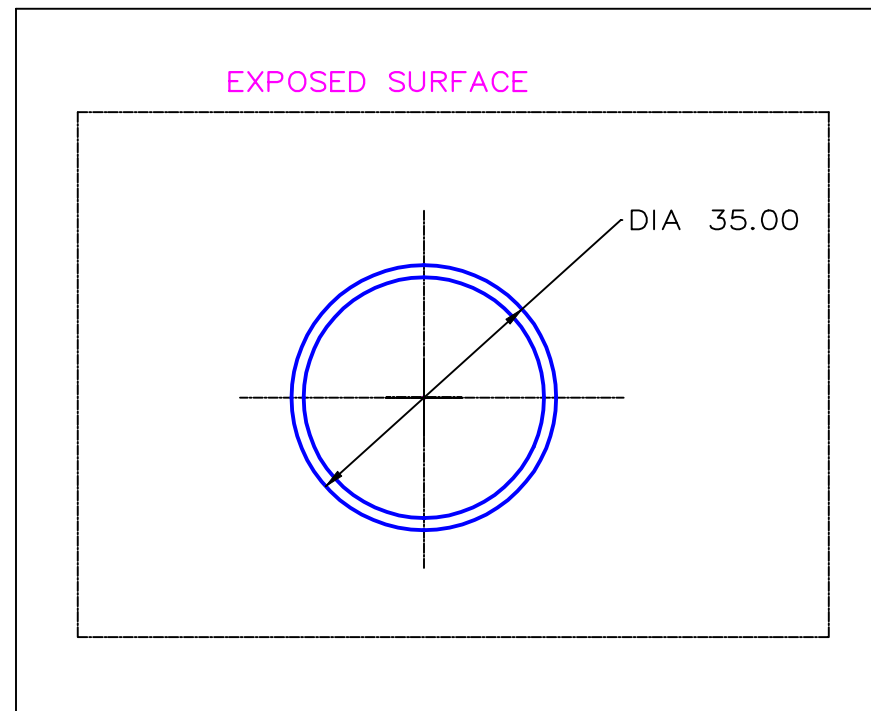

SECTION DATA:
 $I_{xx} = 23\,465 \text{ mm}^4$
 $I_{yy} = 23\,465 \text{ mm}^4$
 $\text{Theta} = 1.0^\circ$
 $\text{RadG}_x = 12. \text{ mm}$
 $\text{RadG}_y = 12. \text{ mm}$
 $X_{\text{Qleft}} = 17.5 \text{ mm}$
 $X_{\text{Qright}} = 17.5 \text{ mm}$
 $Y_{\text{Qtop}} = 17.5 \text{ mm}$
 $Y_{\text{Qbot}} = 17.5 \text{ mm}$
 $Z_{xx\text{top}} = 1\,341 \text{ mm}^3$
 $Z_{xx\text{bot}} = 1\,341 \text{ mm}^3$
 $Z_{yy\text{left}} = 1\,341 \text{ mm}^3$
 $Z_{yy\text{right}} = 1\,341 \text{ mm}^3$

1.6 TYP WALL THICKNESS
 UNLESS OTHERWISE SPECIFIED

0.40 RADIUS ON ALL OUTSIDE CORNERS
 UNLESS OTHERWISE SPECIFIED

EXTRUDED FINISH : ARCHITECTURAL

			A	AREA 167.9 WEIGHT 0.455 PERIMETER 209.9 ANOD PERIM 110.0 PAINT PERIM 110.0 C CIRCLE DIA 35. FACTOR 461. ALLOY 6063 TEMPER T6	SQ MM KG M MM MM MM	 A.C.N 010 828 234 1082 KINGSFORD SMITH DRIVE, EAGLE FARM, QUEENSLAND, 4009 PO BOX 1376, EAGLE FARM BC, 4009 PHONE : (07) 3877 2833 FAX : (07) 3877 2890	CUSTOMER		G.JAMES EXTRUSION Co.					
							CUSTOMER PART NAME		NO.		35 x 1.6 ROUND TUBE			
							SCALE		TOLERANCES IN ACCORDANCE WITH AS 1866-1986 APPLY UNLESS OTHERWISE SPECIFIED					
							DRAWN		CHECK		DATE		DWG. NO.	
							BPW				13/06/90		950-098	
NO	DATE	DR	REVISION											