

SECTION NO.
950-059

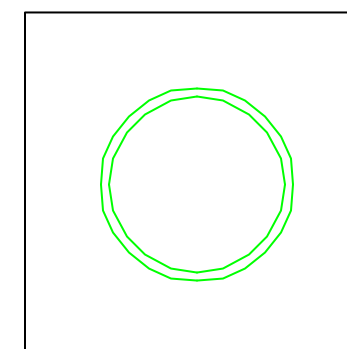
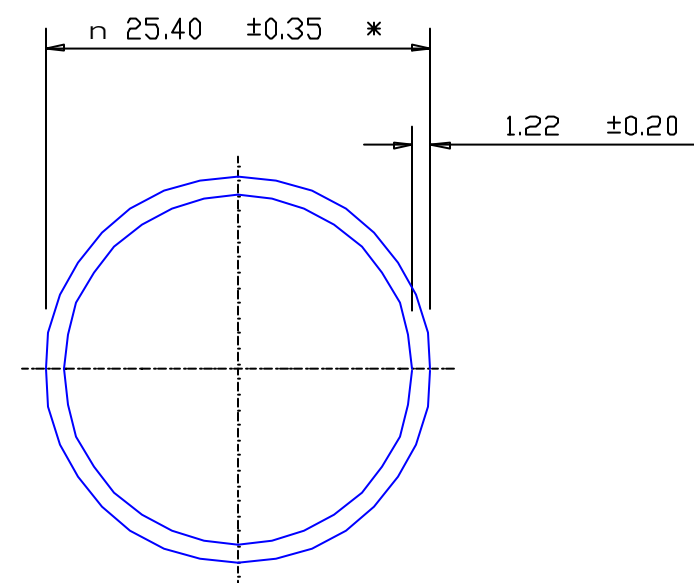

EXPOSED SURFACE
ACTUAL SIZE

* = 1/2 STD TOLERANCE

SECTION DATA:
 $I_{xx} = 6\,790\text{ mm}^4$
 $I_{yy} = 6\,790\text{ mm}^4$
 $\text{Theta} = 0^\circ$
 $\text{RadG}_x = 9\text{ mm}$
 $\text{RadG}_y = 9\text{ mm}$
 $\text{XC}_{\text{Right}} = 12.7\text{ mm}$
 $\text{XC}_{\text{Left}} = 12.7\text{ mm}$
 $\text{YC}_{\text{top}} = 12.7\text{ mm}$
 $\text{YC}_{\text{bot}} = 12.7\text{ mm}$
 $Z_{xx\text{top}} = 535\text{ mm}^3$
 $Z_{xx\text{bot}} = 535\text{ mm}^3$
 $Z_{yy\text{right}} = 535\text{ mm}^3$
 $Z_{yy\text{left}} = 535\text{ mm}^3$

0.40 RADIUS ON ALL OUTSIDE CORNERS
UNLESS OTHERWISE SPECIFIED

EXTRUDED FINISH | ARCHITECTURAL

			A	AREA 92.7 SQ MM WEIGHT 0.251 KG M PERIMETER 151.9 MM ANOD PERIM 79.8 MM PAINT PERIM 100.0 (0.0) MM C CIRCLE DIA 25 MM FACTOR 605 ALLOY 6063 TEMPER T5	 A.C.N 010 828 234 1082 KINGSFORD SMITH DRIVE, EAGLE FARM, QUEENSLAND, 4009 PO BOX 1376, EAGLE FARM BC, 4009 PHONE : (07) 3877 2833 FAX : (07) 3877 2890	CUSTOMER G. JAMES EXTRUSION Co.	
					CUSTOMER PART NAME NO. 25.40 x 1.22 ROUND TUBE		
					SCALE 2:1	TOLERANCES IN ACCORDANCE WITH AS 1866-1987 APPLY UNLESS OTHERWISE SPECIFIED	
NO	DATE	DR	REVISION		DRAWN SPG	CHECK DATE 04/06/02	DWG. NO. 950-059