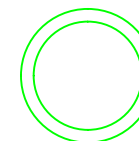
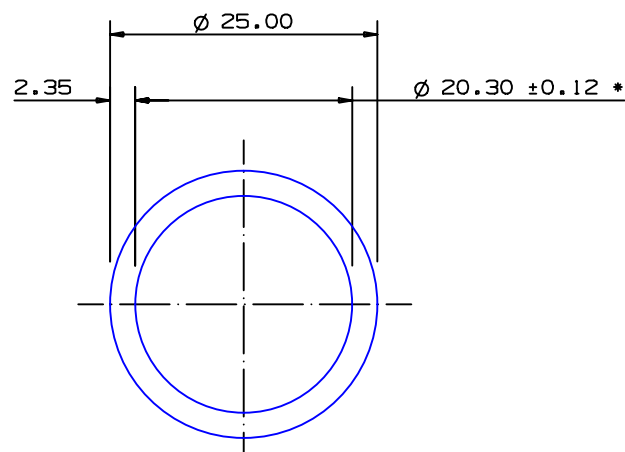

SECTION NO.

950-057

ACTUAL SIZE
NO EXPOSED SURFACE

* = 1/2 STANDARD TOLERANCE

SECTION DATA:

$I_{xx} = 10\,839\text{ mm}^4$
 $I_{yy} = 10\,839\text{ mm}^4$
 $\text{Theta} = 1.0^\circ$
 $\text{RadG}_x = 8\text{ mm}$
 $\text{RadG}_y = 8\text{ mm}$
 $\text{XC}_{\text{Right}} = 12.5\text{ mm}$
 $\text{XC}_{\text{Left}} = 12.5\text{ mm}$
 $\text{YC}_{\text{top}} = 12.5\text{ mm}$
 $\text{YC}_{\text{bot}} = 12.5\text{ mm}$
 $\text{Z}_{\text{xx}}^{\text{top}} = 867\text{ mm}^3$
 $\text{Z}_{\text{xx}}^{\text{bot}} = 867\text{ mm}^3$
 $\text{Z}_{\text{yy}}^{\text{right}} = 867\text{ mm}^3$
 $\text{Z}_{\text{yy}}^{\text{left}} = 867\text{ mm}^3$

0.40 RADIUS ON ALL OUTSIDE CORNERS
UNLESS OTHERWISE SPECIFIED

EXTRUDED FINISH : ARCHITECTURAL

A

AREA	167.2	SQ MM
WEIGHT	0.453	KG M
PERIMETER	142.3	MM
ANOD PERIM	78.5	MM
PAINT PERIM	100.0 (0.0)	MM
C CIRCLE DIA	25	MM
FACTOR	314	
ALLOY	6063	
TEMPER	T6	

**G. James
Extrusion Co.**

A.C.N 010 828 234
 1082 KINGSFORD SMITH DRIVE, EAGLE FARM, QUEENSLAND, 4009
 PO BOX 1376, EAGLE FARM BC, 4009
 PHONE : (07) 3877 2833 FAX : (07) 3877 2890

© COPYRIGHT 2004
 THIS DRAWING IS THE PROPERTY OF
 G. JAMES EXTRUSION CO. PTY LTD
 ALL RIGHTS RESERVED

CUSTOMER

G. JAMES EXTRUSION Co.

CUSTOMER PART NAME

NO.

25 x 2.35 ROUND TUBE

SCALE

2:1

TOLERANCES IN ACCORDANCE WITH AS/NZS 1866:1997
 APPLY UNLESS OTHERWISE SPECIFIED

DRAWN

BPW

CHECK

DATE

22/07/92

DWG. NO.

950-057

1 04/08/92 BPW 20.30 2.35 WAS 20.0 2.50 C/N 1090

NO DATE DR REVISION