

SECTION NO.  
950-042

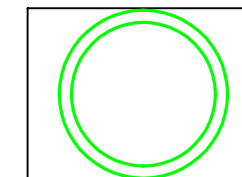
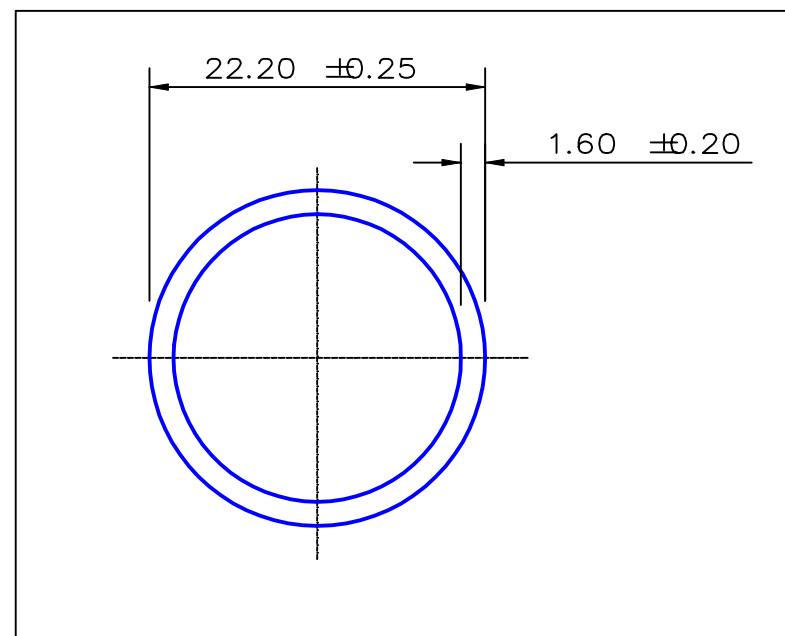

TOTAL EXPOSED SURFACE  
ACTUAL SIZE

SECTION DATA:  
 $I_{xx} = 5\,526 \text{ mm}^4$   
 $I_{yy} = 5\,526 \text{ mm}^4$   
 $\text{Theta} = 1.0$   
 $\text{RadG}_x = 7. \text{ mm}$   
 $\text{RadG}_y = 7. \text{ mm}$   
 $X_{\text{Cleft}} = 11.1 \text{ mm}$   
 $X_{\text{Cright}} = 11.1 \text{ mm}$   
 $Y_{\text{Ctop}} = 11.1 \text{ mm}$   
 $Y_{\text{Cbot}} = 11.1 \text{ mm}$   
 $Z_{xx\text{top}} = 498 \text{ mm}^3$   
 $Z_{xx\text{bot}} = 498 \text{ mm}^3$   
 $Z_{yy\text{left}} = 498 \text{ mm}^3$   
 $Z_{yy\text{right}} = 498 \text{ mm}^3$

0.40 RADIUS ON ALL OUTSIDE CORNERS  
UNLESS OTHERWISE SPECIFIED

EXTRUDED FINISH : ARCHITECTURAL

				A		AREA	103.5	SQ MM	 G. James Extrusion Co. A.C.N 010 828 234 1082 KINGSFORD SMITH DRIVE, EAGLE FARM, QUEENSLAND, 4009 PO BOX 1376, EAGLE FARM BC, 4009 PHONE : (07) 3877 2833 FAX : (07) 3877 2890	CUSTOMER			G. JAMES EXTRUSION Co.				
						WEIGHT	0.281	KG M		CUSTOMER PART NAME			NO.				
						PERIMETER	129.4	MM		22.2 x 1.6			ROUND TUBE				
						ANOD PERIM	69.7	MM		SCALE		TOLERANCES IN ACCORDANCE WITH AS 1866-1986 APPLY UNLESS OTHERWISE SPECIFIED					
						PAINT PERIM	100.0	MM		2:1							
						C CIRCLE DIA	22.	MM									
						FACTOR	461.										
						ALLOY	6063			DRAWN		CHECK		DATE		DWG. NO.	
						TEMPER	T6			AT.				08/05/87		950-042	
NO	DATE	DR	REVISION														