

SECTION NO.

950-032

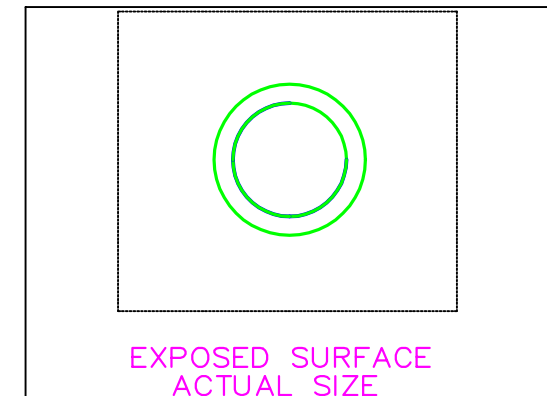
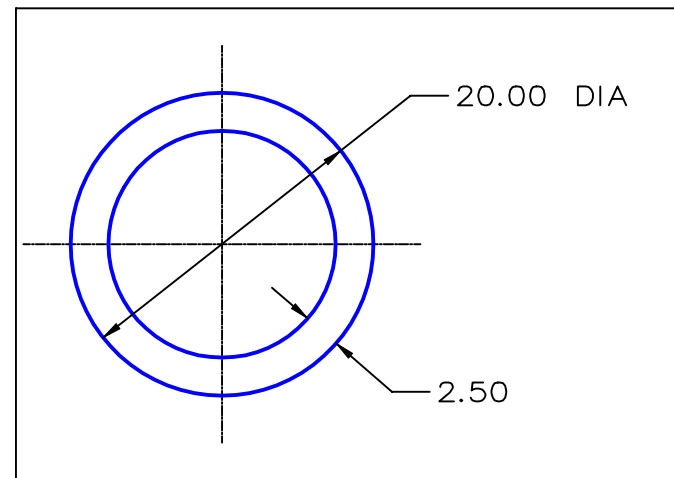

SECTION DATA:
 $I_{xx} = 5\,369\text{ mm}^4$
 $I_{yy} = 5\,369\text{ mm}^4$
 $\text{Theta} = 1.0^\circ$
 $\text{RadG}_x = 6.0\text{ mm}$
 $\text{RadG}_y = 6.0\text{ mm}$
 $X_{Q_{\text{left}}} = 10.0\text{ mm}$
 $X_{Q_{\text{right}}} = 10.0\text{ mm}$
 $Y_{Q_{\text{top}}} = 10.0\text{ mm}$
 $Y_{Q_{\text{bot}}} = 10.0\text{ mm}$
 $Z_{xx_{\text{top}}} = 537\text{ mm}^3$
 $Z_{xx_{\text{bot}}} = 537\text{ mm}^3$
 $Z_{yy_{\text{left}}} = 537\text{ mm}^3$
 $Z_{yy_{\text{right}}} = 537\text{ mm}^3$

0.40 RADIUS ON ALL OUTSIDE CORNERS
 UNLESS OTHERWISE SPECIFIED

EXTRUDED FINISH : ARCHITECTURAL

			A	AREA 137.4 SQ MM WEIGHT 0.372 KG M PERIMETER 110.0 MM ANOD PERIM 62.8 MM PAINT PERIM 100.0 MM C CIRCLE DIA 20.0 MM FACTOR 295. ALLOY 6063 TEMPER T6	 A.C.N 010 828 234 1082 KINGSFORD SMITH DRIVE, EAGLE FARM, QUEENSLAND, 4009 PO BOX 1376, EAGLE FARM BC, 4009 PHONE : (07) 3877 2833 FAX : (07) 3877 2890	CUSTOMER G.JAMES EXTRUSION Co. CUSTOMER PART NAME NO. 20 x 2.5 ROUND TUBE		
					SCALE 2:1	TOLERANCES IN ACCORDANCE WITH AS 1866-1986 APPLY UNLESS OTHERWISE SPECIFIED		
NO	DATE	DR	REVISION		DRAWN JSO	CHECK	DATE 10/05/93	DWG. NO. 950-032