

SECTION NO.
950-031

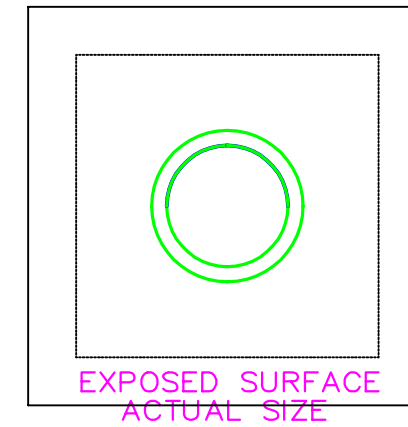
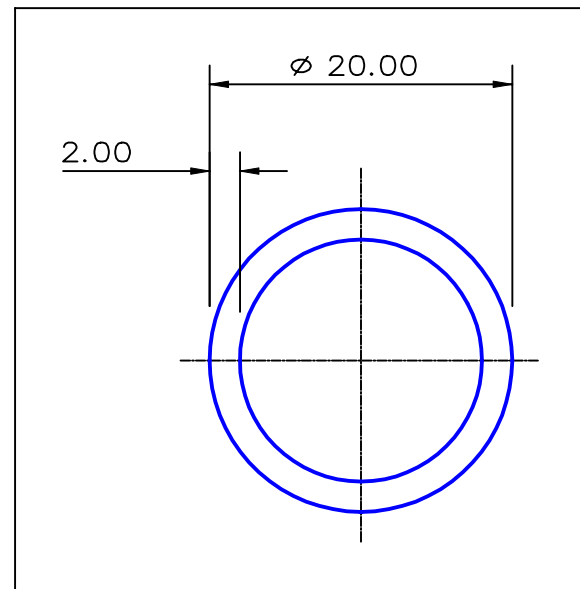

SECTION DATA:
 $I_{xx} = 4\,637\text{ mm}^4$
 $I_{yy} = 4\,637\text{ mm}^4$
 $\text{Theta} = 1.0^\circ$
 $\text{RadG}_x = 6.0\text{ mm}$
 $\text{RadG}_y = 6.0\text{ mm}$
 $X_{\text{Right}} = 10.0\text{ mm}$
 $X_{\text{Left}} = 10.0\text{ mm}$
 $Y_{\text{Top}} = 10.0\text{ mm}$
 $Y_{\text{Bot}} = 10.0\text{ mm}$
 $Z_{xx}^{\text{top}} = 464\text{ mm}^3$
 $Z_{xx}^{\text{bot}} = 464\text{ mm}^3$
 $Z_{yy}^{\text{right}} = 464\text{ mm}^3$
 $Z_{yy}^{\text{left}} = 464\text{ mm}^3$

0.40 RADIUS ON ALL OUTSIDE CORNERS
UNLESS OTHERWISE SPECIFIED

EXTRUDED FINISH : ARCHITECTURAL

			B	AREA 113.1 SQ MM WEIGHT 0.306 KG M PERIMETER 113.1 MM ANOD PERIM 62.8 MM PAINT PERIM 100.0 (0.0) MM C CIRCLE DIA 20. MM FACTOR 369. ALLOY 6063 TEMPER T6	 A.C.N 010 828 234 1082 KINGSFORD SMITH DRIVE, EAGLE FARM, QUEENSLAND, 4009 PO BOX 1376, EAGLE FARM BC, 4009 PHONE : (07) 3877 2833 FAX : (07) 3877 2890	CUSTOMER G. JAMES EXTRUSION Co.		
						CUSTOMER PART NAME NO. 20 x 2.0 ROUND TUBE		
						SCALE 2:1	TOLERANCES IN ACCORDANCE WITH AS 1866-1986 APPLY UNLESS OTHERWISE SPECIFIED	
NO	DATE	DR	REVISION			DRAWN BPW	CHECK DATE 27/02/91	DWG. NO. 950-031