

SECTION NO.

950-030

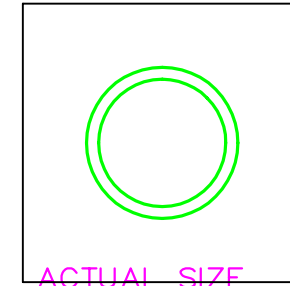
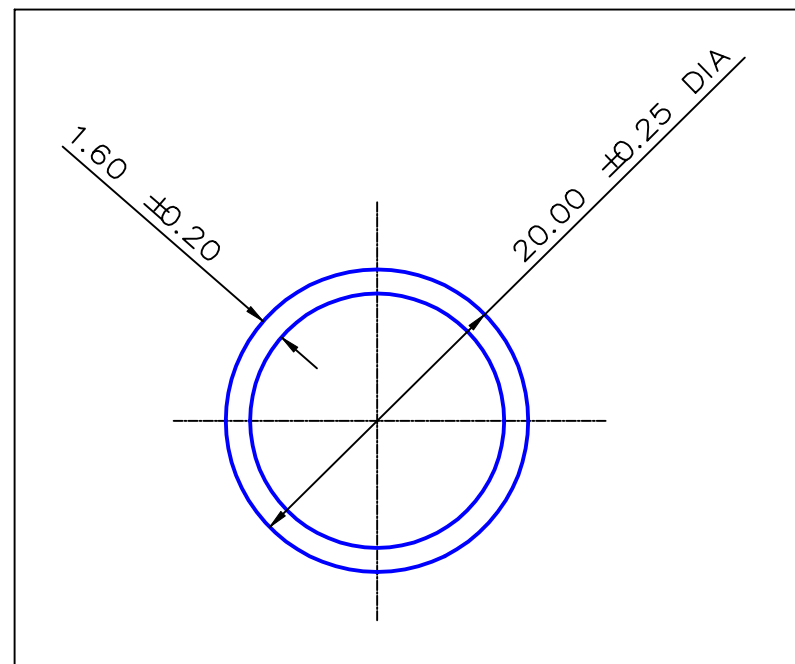

ACTUAL SIZE  
OUTSIDE SURFACE EXPOSED

SECTION DATA:

$I_{XX} = 3\,944 \text{ mm}^4$   
 $I_{YY} = 3\,944 \text{ mm}^4$   
 $\text{Theta} = 45.0^\circ$   
 $\text{RadG}_x = 7. \text{ mm}$   
 $\text{RadG}_y = 7. \text{ mm}$   
 $X_{\text{Left}} = 10.0 \text{ mm}$   
 $X_{\text{Right}} = 10.0 \text{ mm}$   
 $Y_{\text{Top}} = 10.0 \text{ mm}$   
 $Y_{\text{Bot}} = 10.0 \text{ mm}$   
 $Z_{xx\text{top}} = 394 \text{ mm}^3$   
 $Z_{xx\text{bot}} = 394 \text{ mm}^3$   
 $Z_{yy\text{left}} = 394 \text{ mm}^3$   
 $Z_{yy\text{right}} = 394 \text{ mm}^3$

0.40 RADIUS ON ALL OUTSIDE CORNERS  
UNLESS OTHERWISE SPECIFIED

EXTRUDED FINISH : ARCHITECTURAL

			<b>B</b>	AREA 92.5 SQ MM WEIGHT 0.251 KG M PERIMETER 115.6 MM ANOD PERIM 62.8 MM PAINT PERIM 100.0 MM C CIRCLE DIA 20. MM FACTOR 461. ALLOY 6063 TEMPER T6	 A.C.N 010 828 234 1082 KINGSFORD SMITH DRIVE, EAGLE FARM, QUEENSLAND, 4009 PO BOX 1376, EAGLE FARM BC, 4009 PHONE : (07) 3877 2833 FAX : (07) 3877 2890	CUSTOMER G. JAMES EXTRUSION Co.		
						CUSTOMER PART NAME NO. 20 x 1.6 ROUND TUBE		
						SCALE 2:1	TOLERANCES IN ACCORDANCE WITH AS 1866-1986 APPLY UNLESS OTHERWISE SPECIFIED	
NO	DATE	DR	REVISION			DRAWN JWC	CHECK DATE 06/04/97	DWG. NO. 950-030