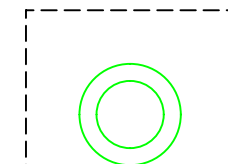
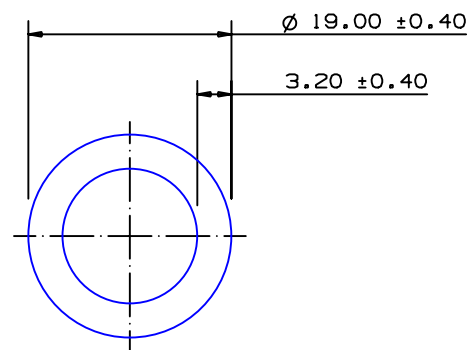

SECTION NO.

950-023

EXPOSED SURFACE
ACTUAL SIZE

SECTION DATA:

$I_{xx} = 5\,160\text{ mm}^4$
 $I_{yy} = 5\,160\text{ mm}^4$
 $\text{Theta} = 1.0^\circ$
 $\text{RadG}_x = 6\text{ mm}$
 $\text{RadG}_y = 6\text{ mm}$
 $\text{XC}_{\text{Right}} = 9.5\text{ mm}$
 $\text{XC}_{\text{Left}} = 9.5\text{ mm}$
 $\text{YC}_{\text{top}} = 9.5\text{ mm}$
 $\text{YC}_{\text{bot}} = 9.5\text{ mm}$
 $Z_{xx\text{top}} = 543\text{ mm}^3$
 $Z_{xx\text{bot}} = 543\text{ mm}^3$
 $Z_{yy\text{right}} = 543\text{ mm}^3$
 $Z_{yy\text{left}} = 543\text{ mm}^3$

0.40 RADIUS ON ALL OUTSIDE CORNERS
UNLESS OTHERWISE SPECIFIED

EXTRUDED FINISH : ARCHITECTURAL

B 42629

AREA	158.8	SQ MM
WEIGHT	0.430	KG M
PERIMETER	99.3	MM
ANOD PERIM	59.7	MM
PAINT PERIM	100.0 (0.0)	MM
C CIRCLE DIA	19	MM
FACTOR	231	
ALLOY	6060	
TEMPER	T581	

**G. James
Extrusion Co.**

A.C.N 010 828 234
 1082 KINGSFORD SMITH DRIVE, EAGLE FARM, QUEENSLAND, 4009
 PO BOX 1376, EAGLE FARM BC, 4009
 PHONE : (07) 3877 2833 FAX : (07) 3877 2890

© COPYRIGHT 2004
 THIS DRAWING IS THE PROPERTY OF
 G.JAMES EXTRUSION CO. PTY LTD
 ALL RIGHTS RESERVED

CUSTOMER

G. JAMES EXTRUSION Co.

CUSTOMER PART NAME

NO.

DIA 19.0 x 3.20 ROUND TUBE

SCALE

2:1

TOLERANCES IN ACCORDANCE WITH AS/NZS 1866:1997
 APPLY UNLESS OTHERWISE SPECIFIED

DRAWN

SPG

CHECK

DATE

28/06/06

DWG. NO.

950-023

NO	DATE	DR	REVISION