

### TEE SECTION

SECTION NUMBER	DESCRIPTION (MM)	MASS KG/M	X VALUE mm <sup>4</sup>	Y VALUE mm <sup>4</sup>	APPL
985 028	32 X 32 X 4/3	0.590	18,648	10,967	S
985 027	32 X 54 X 4	0.907	99,784	11,196	S
970 075	38 X 38 X 4	0.799	39,467	18,533	S
985 020	40 X 40 X 3	0.645	36,169	16,126	S
970 092	40 X 40 X 4	0.842	46,376	21,587	S
ICT 004	40 X 60 X 3.5/3	1.253	140,263	22,647	S
ICT 005	40 X 70 X 4/3	1.428	239,011	22,899	S
ICT 014	40 X 80 X 4.5/3	1.630	376,589	23,222	S

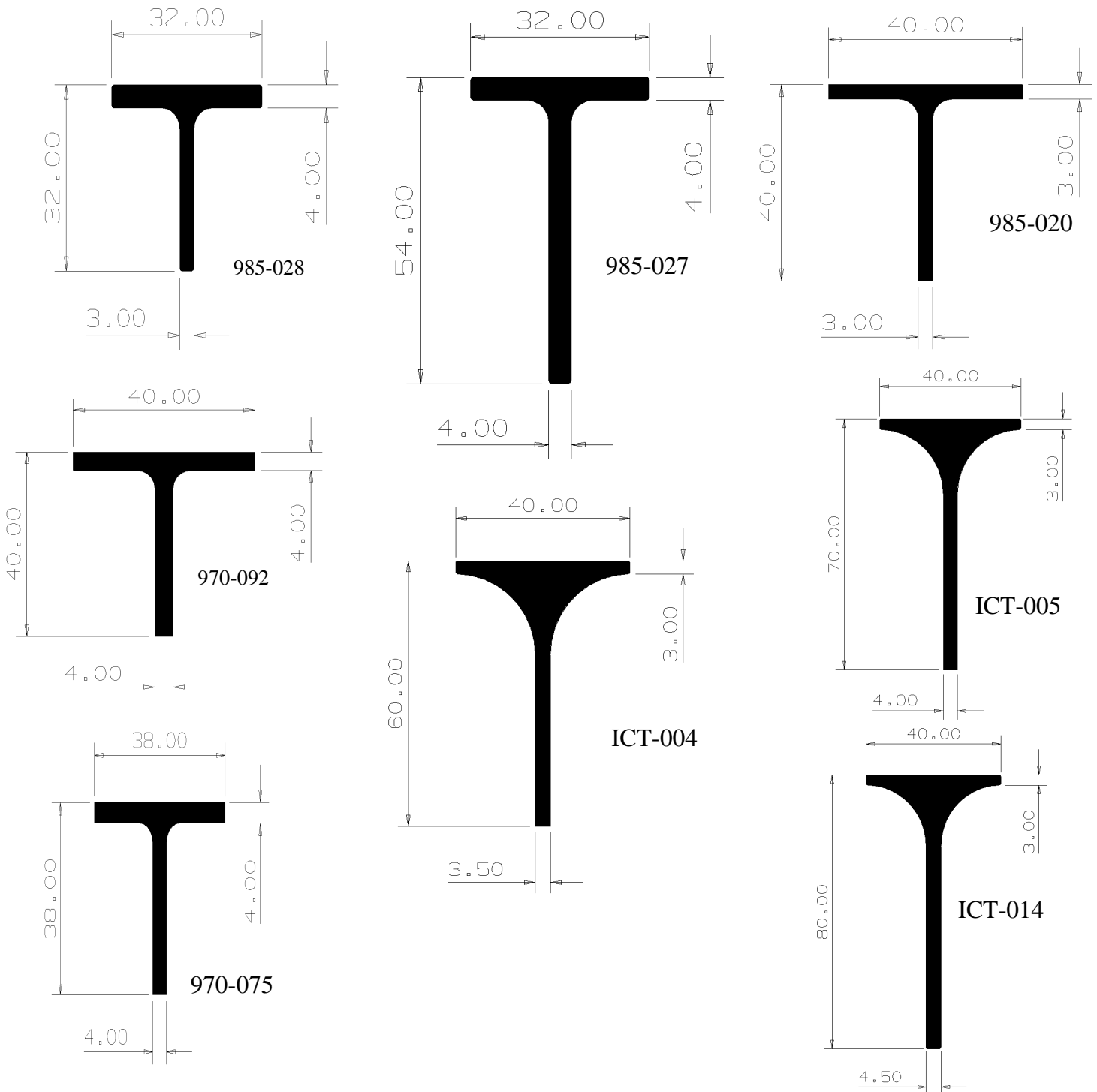

### TEE SECTION

SECTION NUMBER	DESCRIPTION (mm)	MASS KG/M	X VALUE mm <sup>4</sup>	Y VALUE mm <sup>4</sup>	APPL
970 093	45 X 100 X 8/5	2.240	834,240	61,683	S
ICT 015	45 X 100 X 4/8	1.991	719,258	61,302	S
985 031	48 X 50 X 4	1.075	90,935	30,024	S
970 099	50 X 50 X 4	1.058	92,998	41,840	S
970 108	50 X 50 X 5	1.306	112,990	52,635	S
970 103	50 X 50 X 6	1.570	132,093	63,603	S
ICT 032	50 X 60 X 4/6	1.417	166,924	62,849	S

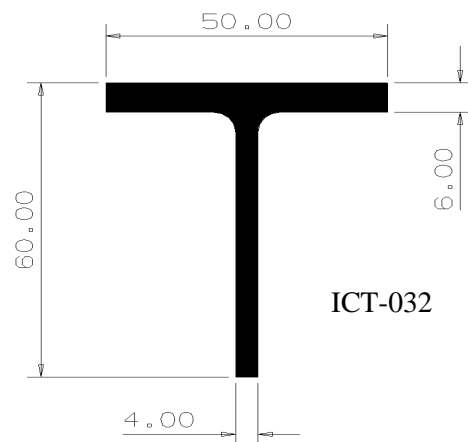
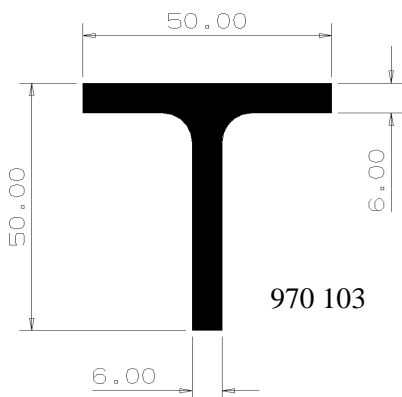
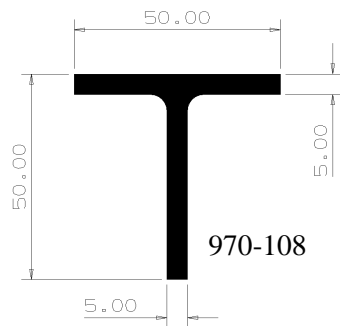
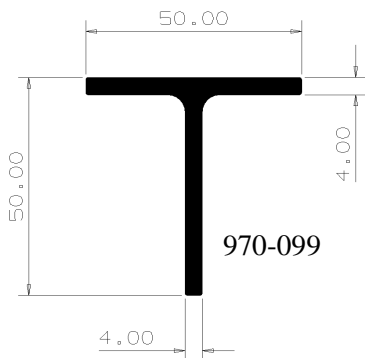
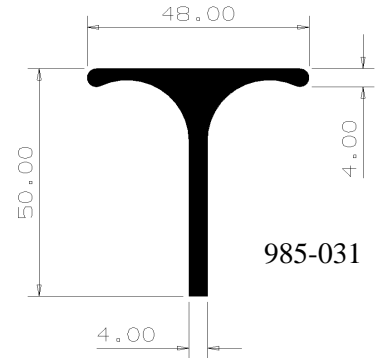
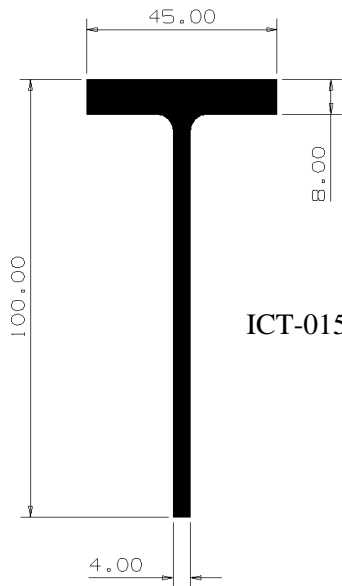
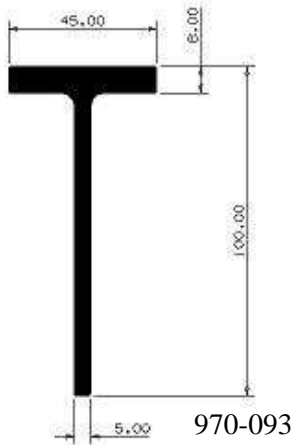

**TEE SECTION**

SECTION NUMBER	DESCRIPTION (mm)	MASS KG/M	X VALUE mm <sup>4</sup>	Y VALUE mm <sup>4</sup>	APPL
ICT 013	50 X 70 X 4/8	1.775	269,602	83,725	S
970 360	50 X 76 X 5	1.658	363,907	52,906	S
ICT 016	50 X 100 X 5.5/3	2.427	885,994	48,825	S
ICT 007	50 X 120 X 6.5/3	3.017	1,639,565	50,523	S

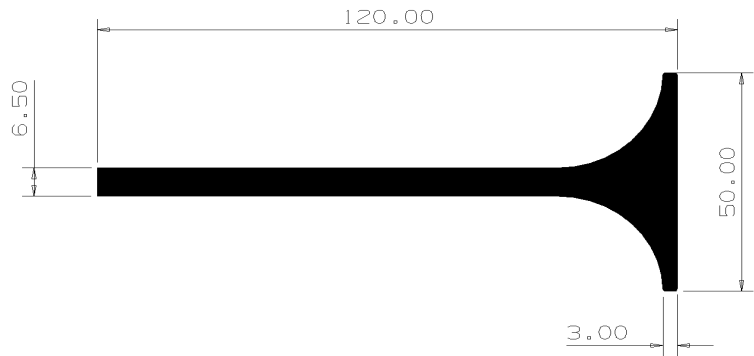
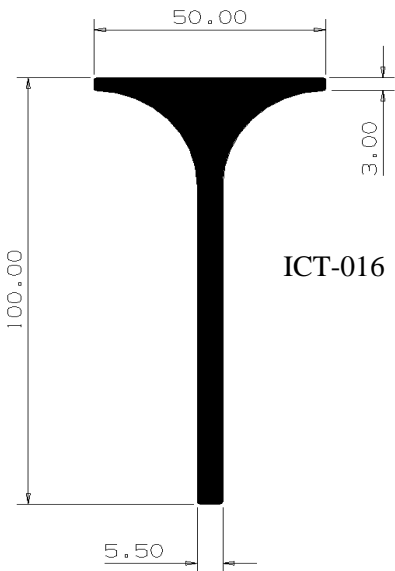
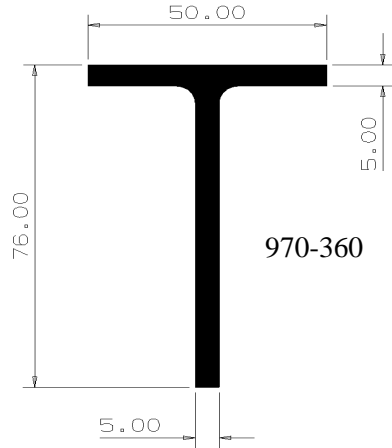
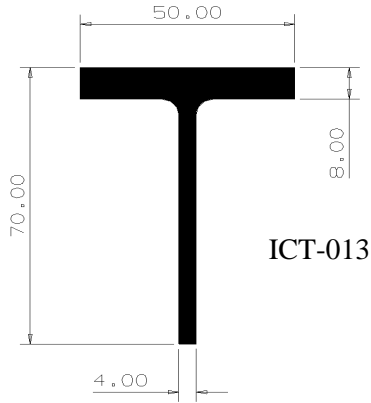

### TEE SECTION

SECTION NUMBER	DESCRIPTION (mm)	MASS KG/M	X VALUE mm <sup>4</sup>	Y VALUE mm <sup>4</sup>	APPL
985 077	60 X 180 X 8/4	5.251	114,038	6,476,987	S
970 104	65 X 65 X 6	2.058	301,755	138,685	S
ICT 017	70 X 140 X 6/10	4.026	291,305	287,240	S

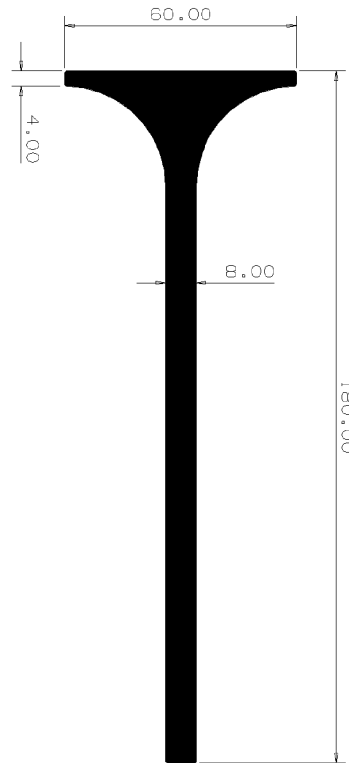
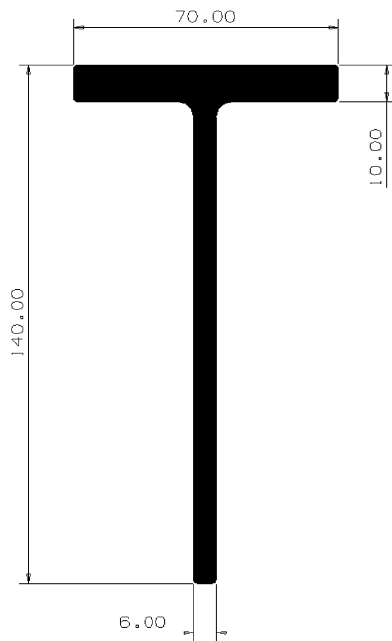
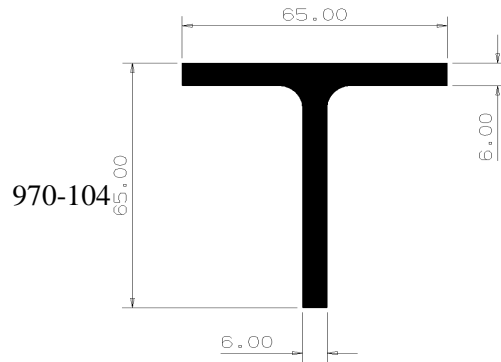

**TEE SECTION**

SECTION NUMBER	DESCRIPTION (mm)	MASS KG/M	X VALUE mm <sup>4</sup>	Y VALUE mm <sup>4</sup>	APPL
970 375	80 X 139 X 8/5	3.625	343,469	2,537,253	S
ICT 003	90 X 90 X 8/6	4.644	1,107,127	507,579	S
985 045	100.9 X 50.6 X 3.2	1.290	94,601	273,524	S
985 053	70.6 X 181.1 X 7.2/10.2	6.332	357,372	7,397,998	S

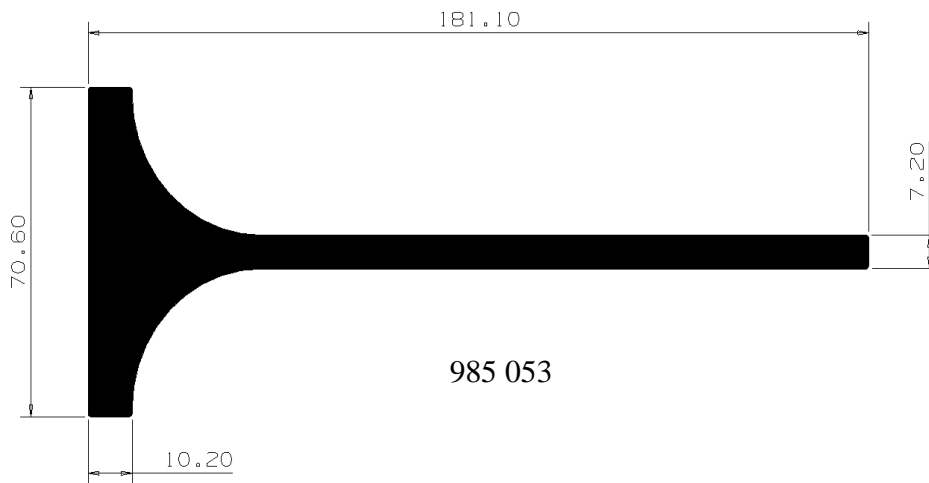
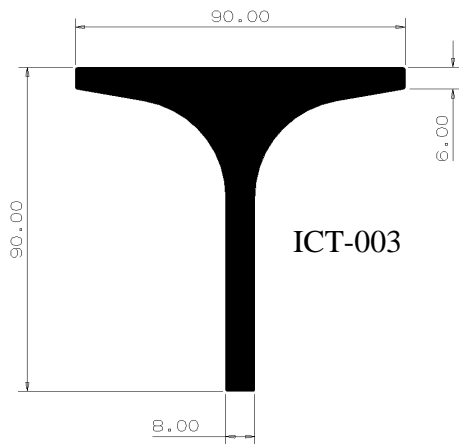
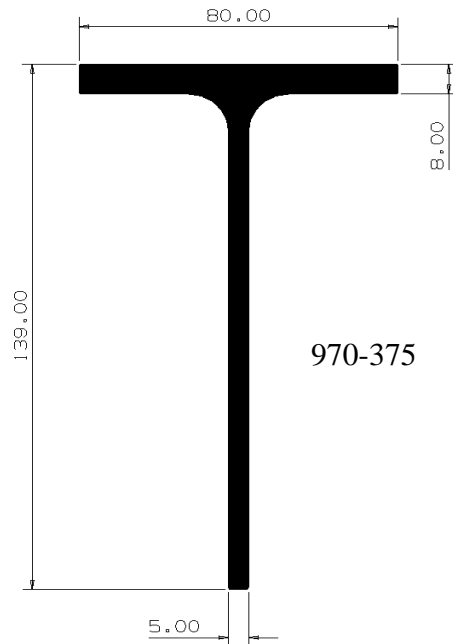
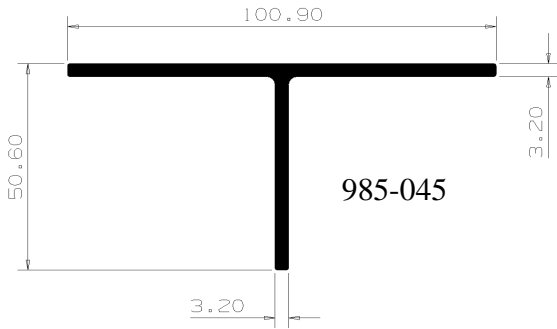

**TEE SECTION**

SECTION NUMBER	DESCRIPTION (mm)	MASS KG/M	X VALUE mm <sup>4</sup>	Y VALUE mm <sup>4</sup>	APPL
985 082	80 X 208 X 6/8	5.025	343,883	8,565,868	S
ICT 095	150 X 200 X 6/10	7.549	2,823,055	11,990,149	S

