

GENERAL – FIT OUT

SECTION NUMBER	DESCRIPTION	MASS KG/M	X VALUE MM ⁴	Y VALUE MM ⁴	APPL
985 080	COVER	1.87	163, 221	979, 020	S
ICT 062	WALL BOARD ANGLE	0.151	1,919	1,919	A
ICT 069	DOOR JAMB	0.744	10,089	84,123	A
ICT 070	DOOR JAMB	1.150	5,611	674,792	A
ICT 071	DOOR CHANNEL	0.404	5,387	35,505	A
ICT 076	CAPING	0.503	1,883	103,674	A
ICT 081	TABLE EDGE – END STRIP	0.278	481	18,683	A

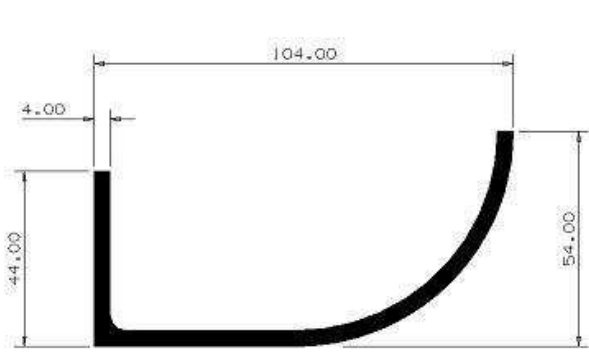

985 080

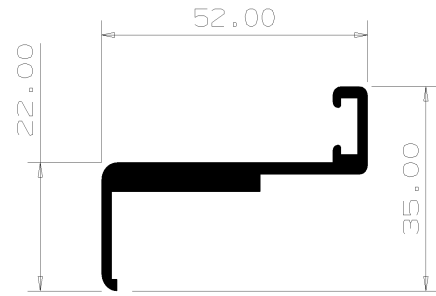

ICT 069

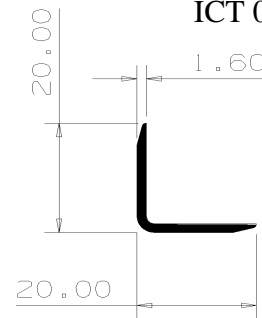

ICT 062

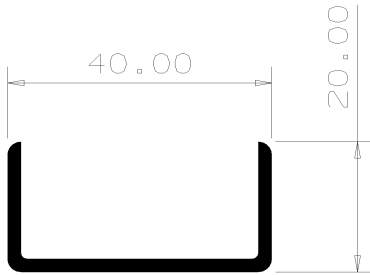

ICT 071

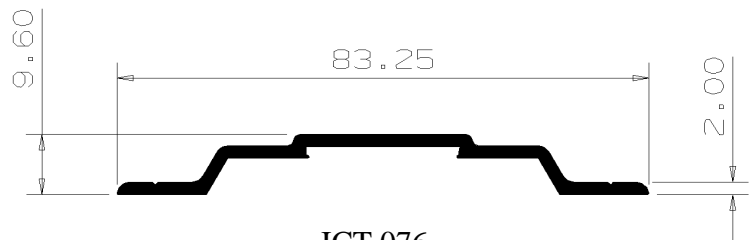

ICT 076



ICT 070

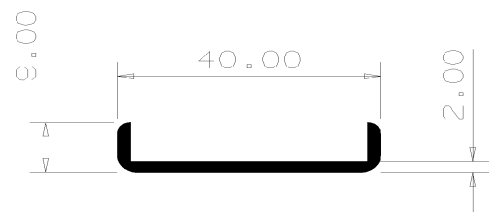

ICT 081

GENERAL – FIT OUT

SECTION NUMBER	DESCRIPTION	MASS KG/M	X VALUE MM ⁴	Y VALUE MM ⁴	APPL
ICT 079	CAPPING	0.820	2,419	481,888	A
ICT 098	WALL BOARD JOINER	0.163	3,131	2,069	A
ICT 100	TABLE LEG	1.722	285,732	285,732	A
ICT 111	DOOR JAMB	0.640	17,107	83,351	A
985 108	COVER	2.017	308, 698	1, 225, 751	S

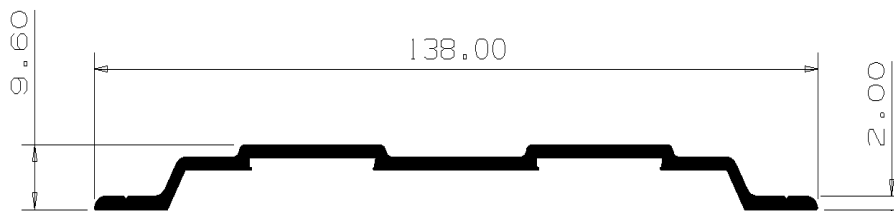

ICT 079

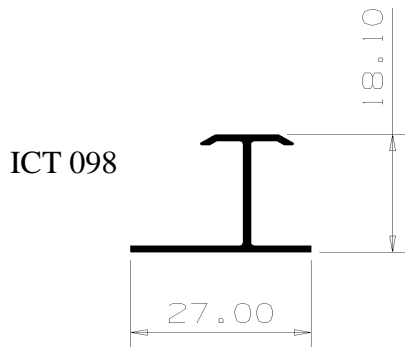

ICT 098

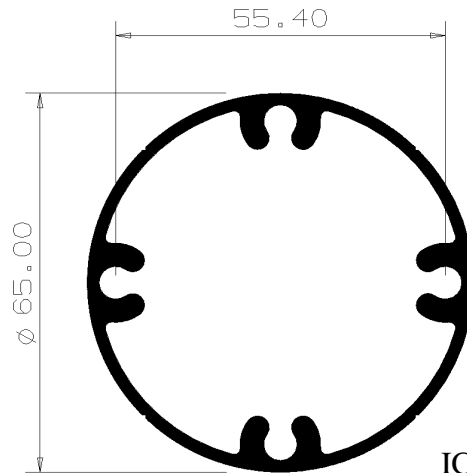

ICT 100

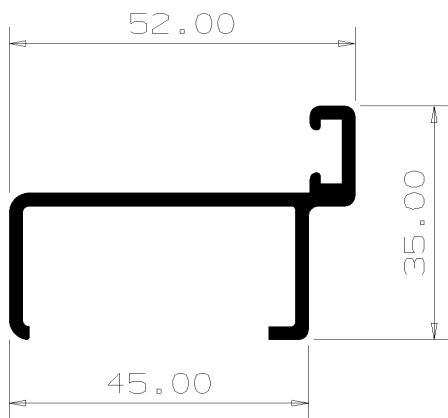

ICT 111

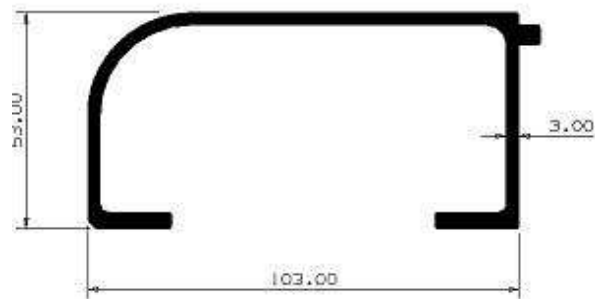

985 108

GENERAL - FIT OUT

SECTION NUMBER	DESCRIPTION	MASS KG/M	X VALUE MM ⁴	Y VALUE MM ⁴	APPL
ICT 112	WALL BOARD JOINER	0.111	523	472	A
ICT 115	WALL BOARD JOINER	0.175	2,648	1,801	A
ICT 122	SKIRTING SECTION	0.297	824	11,499	A
983 021	CEILING BEAM	0.435	35,908	19,708	A

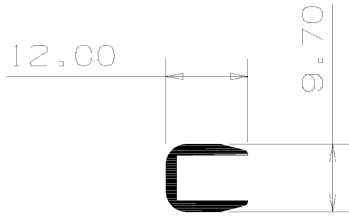

ICT 112

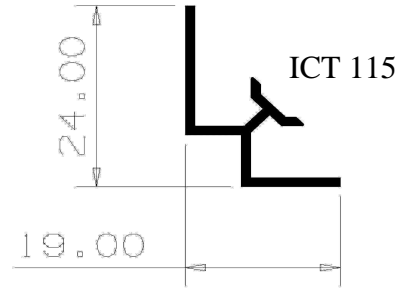

ICT 115

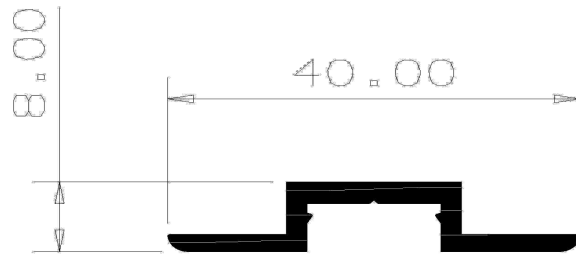

ICT 122

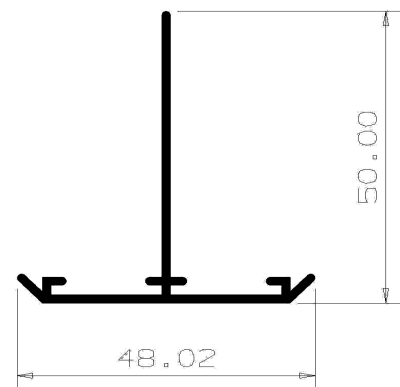

983 021

GENERAL - FIT OUT

SECTION NUMBER	DESCRIPTION	MASS KG/M	X VALUE MM ⁴	Y VALUE MM ⁴	APPL
ICT 008	END STRIP/TABLE EDGE	0.168	3,037	384	A
ICT 021	LOUVER	0.441	76,197	21,491	A
ICT 056	POST	0.752	40,725	35,522	A
ICT 057	POST	0.769	42,592	101,636	A
ICT 058	HAND RAIL CAP	1.479	39,473	239,642	A

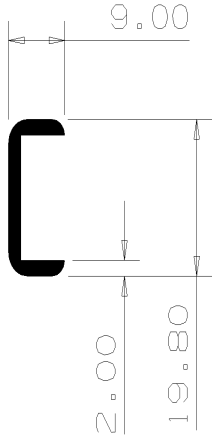

ICT 008

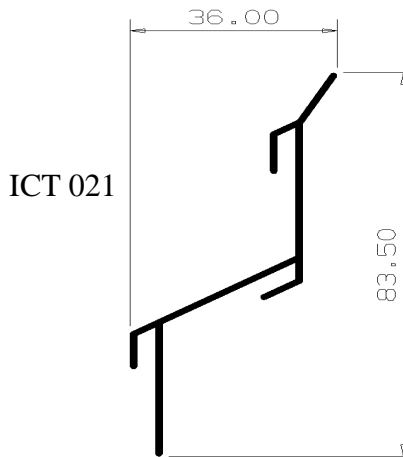

ICT 021

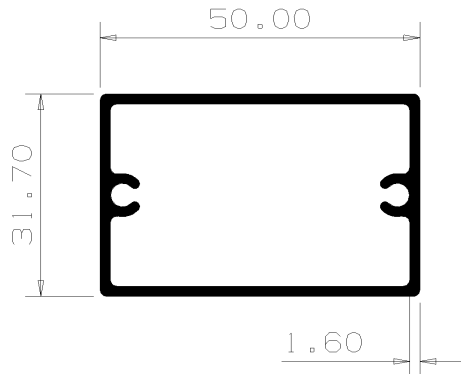

ICT 057

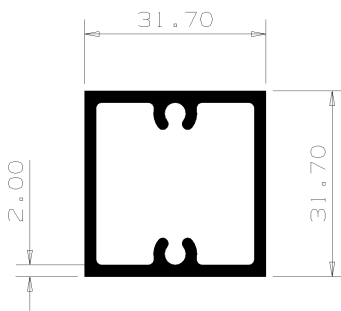

ICT 056

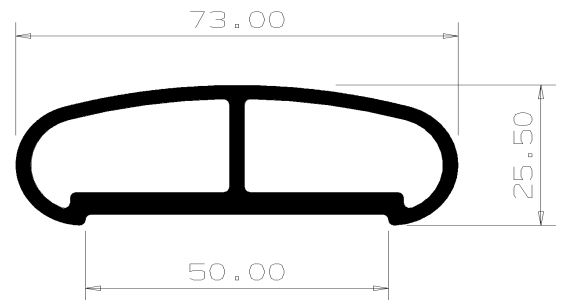

ICT 058

GENERAL - FIT OUT

SECTION NUMBER	DESCRIPTION	MASS KG/M	X VALUE MM ⁴	Y VALUE MM ⁴	APPL
ICT 094	WALL BOARD JOINER	0.133	625	2,028	A
ICT 048	CEILING TEE ROD	0.053	31	31	A
985 050	SIGN CHANNEL	3.525	275,460	14,880,595	A
985 047	WALL BOARD JOINER	0.173	346	6,054	A
985 081	TOP HAT	0.187	880	4,207	A
ICT 081	TABLE EDGE – END STRIP	0.278	481	18,683	A
983 211	EDGING HOLDER	1.211	171,941	199,049	A

