

## FLOORING

SECTION NUMBER	DESCRIPTION (mm)	MASS KG/M	X VALUE mm <sup>4</sup>	Y VALUE mm <sup>4</sup>	APPL
985 057	VEHICLE DECK 306.5 X 60.8	9.938	2,227,914	28,823,878	S
985 055	VEHICLE DECK 306.5 X 61.2	10.261	2,332,803	29,719,735	S
985 109	320MM BOAT DECKING	4.009	245, 851	14, 137, 140	S

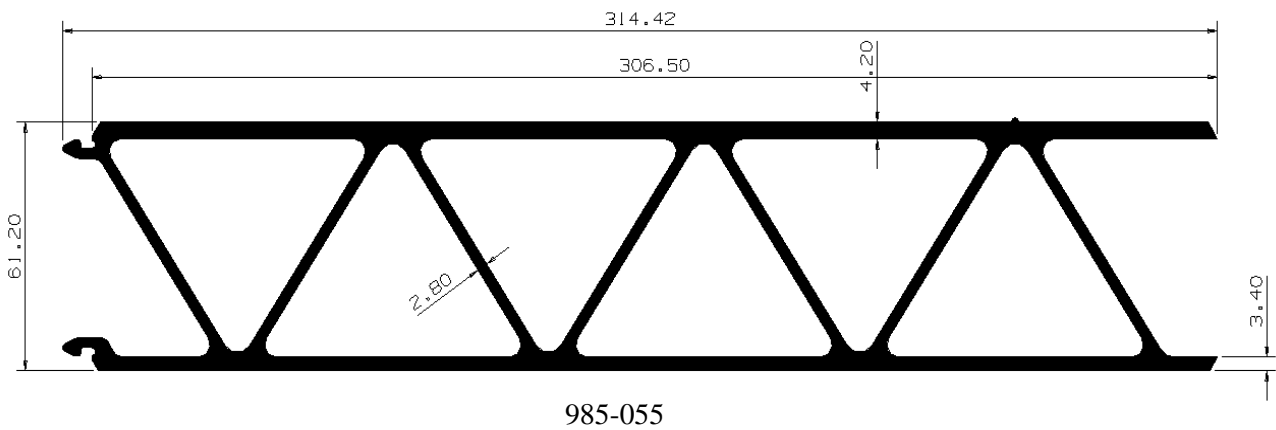
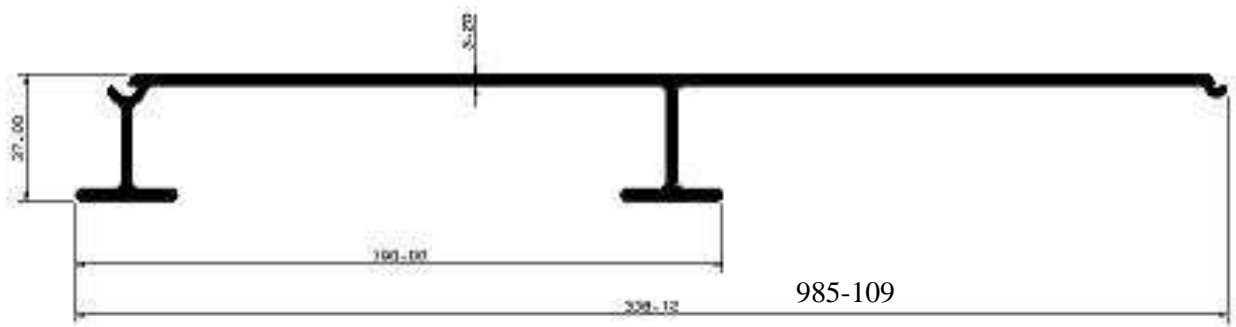
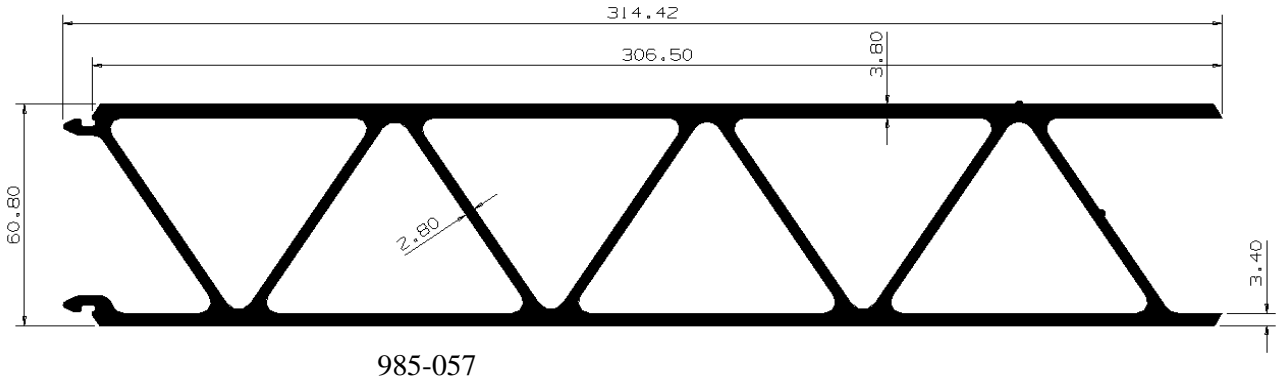

**FLOORING**

SECTION NUMBER	DESCRIPTION (mm)	MASS KG/M	X VALUE mm <sup>4</sup>	Y VALUE mm <sup>4</sup>	APPL
ICT 163	LIGHT VEHICLE DECK 317.5 X 25	4.749	192,886	17,022,887	S

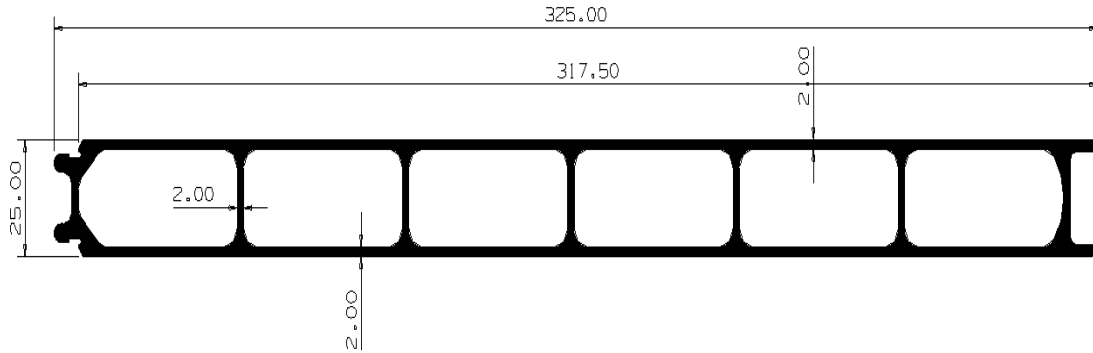

ICT-163

**FLOORING**

SECTION NUMBER	DESCRIPTION (mm)	MASS KG/M	X VALUE mm <sup>4</sup>	Y VALUE mm <sup>4</sup>	APPL
ICT 077	FLOORING 201.8 X 66	2.676	663,801	3,804,257	S
985 017	FLOORING 250 X 33	2.977	117,842	6,748,785	S
985 023	FLOORING 250 X 37	2.115	143,976	4,661,438	S
985 030	FLOORING 302.7 X 67	6.142	1,182,141	20,675,191	S

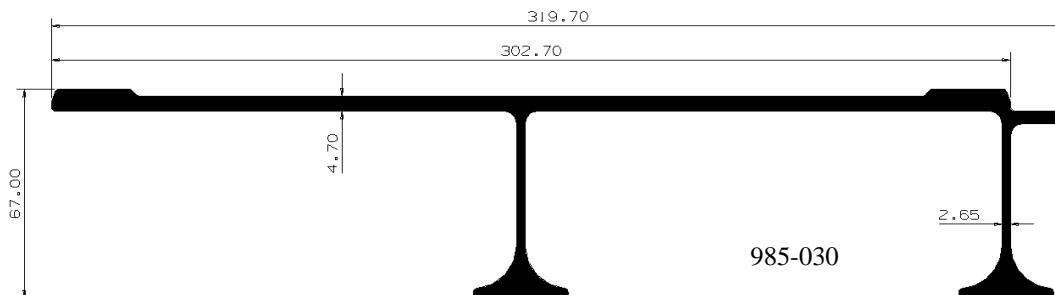
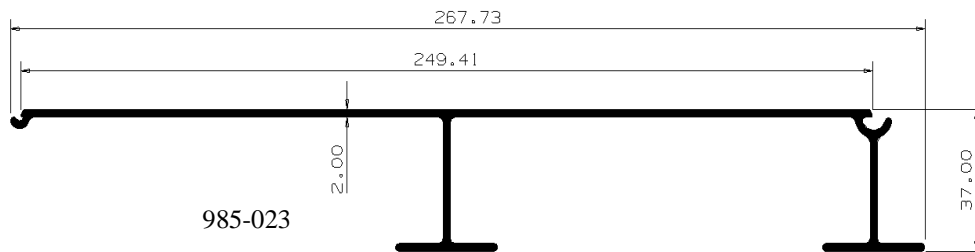
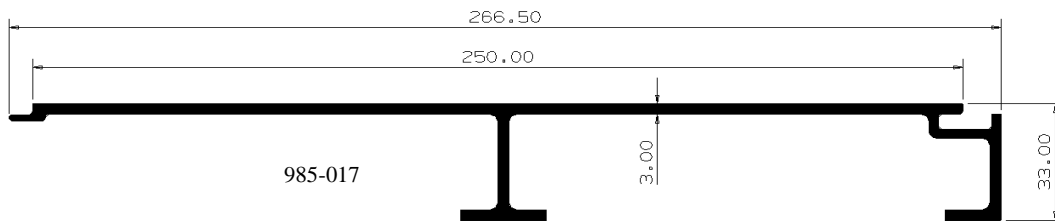
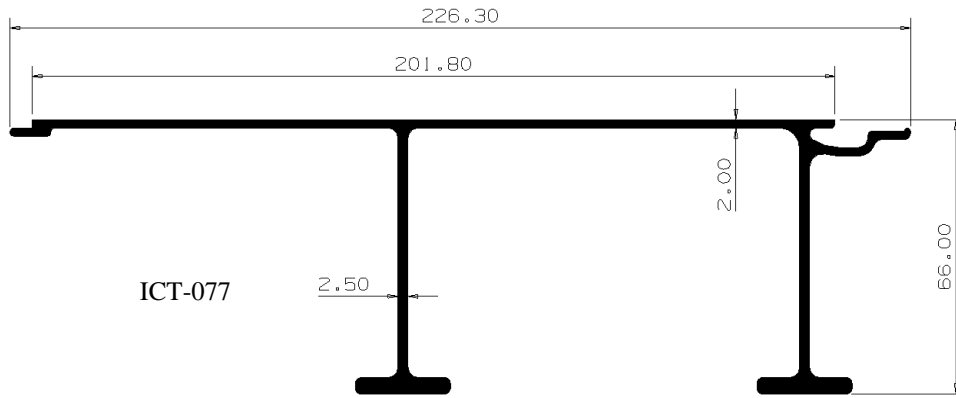

FLOORING

SECTION NUMBER	DESCRIPTION (mm)	MASS KG/M	X VALUE mm <sup>4</sup>	Y VALUE mm <sup>4</sup>	APPL
985 036	FLOORING 319 X 37	3.740	237,319	13,275,350	S
ICT 030	FLOORING 317 X 32.5	2.474	96,988	9,140,381	S
985 096	FLOORING 317 X 32.5	2.942	10,157,728	S	
ICT 134	FLOORING/STARTER 80 X 32.5	1.107	55,170	595,670	S

